

# MODEL 4WG

100 - 800 HP  
Steam and Hot Water  
Wet-back Packaged Burner

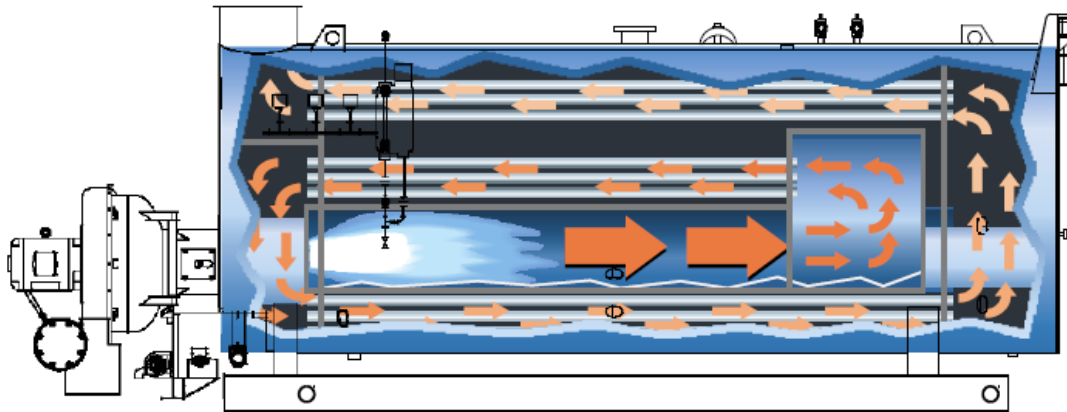

## CONTENTS

FEATURES AND BENEFITS .....	A3-3
PRODUCT OFFERING .....	A3-3
DIMENSIONS AND RATINGS .....	A3-4
PERFORMANCE DATA .....	A3-14
ENGINEERING DATA.....	A3-15
Burner/Control Information .....	A3-15
Boiler Room Information.....	A3-16
Stack Support Capabilities.....	A3-16
Boiler Room Combustion Air .....	A3-16
Stack/Breeching Size Criteria.....	A3-18
SAMPLE SPECIFICATIONS Model 4WG STEAM BOILERS.....	A3-25
SAMPLE SPECIFICATIONS Model 4WG HOT WATER BOILERS .....	A3-37

**ILLUSTRATIONS**

Figure A3-1. 4WG - Steam 100-800 HP ..... A3-5  
 Figure A3-2. 4WG - Hot Water 100-800 HP ..... A3-7  
 Figure A3-3. 4WG Low NOx - Steam 100-800 HP ..... A3-9  
 Figure A3-4. 4WG Low NOx - Hot Water 100-800 HP ..... A3-11  
 Figure A3-5. Space Required to Open Rear Head on Model 4WG ..... A3-13  
 Figure A3-6. Model 4WG Lift Lug Locations ..... A3-13  
 Figure A3-7. Model 4WG Mounting Piers ..... A3-14  
 Figure A3-8. Typical Fuel Oil Supply Arrangement ..... A3-23  
 Figure A3-9. Boiler Room Length (Typical Layouts) - Model 4WG ..... A3-24  
 Figure A3-10. Boiler Room Width (Typical Layouts) - Model 4WG ..... A3-24

**TABLES**

Table A3-1. 4WG Ratings - Steam ..... A3-5  
 Table A3-2. 4WG Dimensions - Steam ..... A3-6  
 Table A3-3. 4WG Ratings - Hot Water ..... A3-7  
 Table A3-4. 4WG Dimensions - Hot Water ..... A3-8  
 Table A3-5. 4WG Low NOx Ratings - Steam ..... A3-9  
 Table A3-6. 4WG Low NOx Dimensions - Steam ..... A3-10  
 Table A3-7. 4WG Low NOx Ratings - Hot Water ..... A3-11  
 Table A3-8. 4WG Low NOx Dimensions - Hot Water ..... A3-12  
 Table A3-9. 4WG Blowdown Tank Sizing Information ..... A3-18  
 Table A3-10. 4WG Boilers: Predicted Sound Levels (30 ppm NOx systems) @ High Fire ..... A3-18  
 Table A3-11. Steam Volume and Disengaging Areas ..... A3-19  
 Table A3-12. Model 4WG Steam Boiler Safety Valve Outlet Size ..... A3-19  
 Table A3-13. Model 4WG Hot Water Relief Valve Outlet Size ..... A3-20  
 Table A3-14. 4WG Recommended Steam Nozzle Size ..... A3-20  
 Table A3-15. 4WG Recommended Non-Return Valve Size ..... A3-21  
 Table A3-16. Altitude Correction for Gas ..... A3-21  
 Table A3-17. Model 4WG, Standard and Low NOx (30 ppm), Minimum Required Gas Pressure at Entrance to Standard, FM and IRI Gas Trains (Upstream of Gas Pressure Regulator) ..... A3-22

## FEATURES AND BENEFITS

The Cleaver-Brooks Model 4WG Boiler provides an integrated boiler burner package with optimized pressure vessel and furnace working in conjunction with a matching Profire gun burner. Additionally, the boiler/burner package is fully UL and cUL approved and available from 100 - 800 hp. The following features apply:

### Four-Pass Wetback Design:

- Four-pass design provides high flue gas velocities and low stack temperatures to maximize efficiency.
- Five square feet of heating surface per boiler horsepower (except for the 750 and 800 hp unless otherwise specified) provides guaranteed efficiency performance and long boiler life.

### Hinged Burner, Front and Rear Doors:

- Hinged burner assembly provides ease of access to the furnace.
- Large rear access plug for turnaround and furnace access.
- Rear door completely covers and insulates rear tube sheet.

### Natural Gas, No. 2 Oil, or Combination Burners Available:

- Combination gas/oil burners provide quick fuel changeover without burner adjustment.

## PRODUCT OFFERING

Cleaver-Brooks Model 4WG Boilers are available in low pressure steam, high pressure steam, and hot water designs. Burners are available to fire natural gas, No. 2 oil, or a combination of oil and gas.

### Standard product offering is:

- 100 - 800 hp.
- 30 and 125 psig hot water.
- 15 - 250 psig steam.
- Full modulation, all sizes.

Available options include the following (contact your local Cleaver-Brooks authorized representative for option details).

### Boiler Options:

- Low NOx emission levels from 75, 30, 15 - <9PPM when burning natural gas and 70 PPM on # 2 oil when the fuel bound nitrogen is at 0.02% or less.
- Drain valves.
- Additional screwed or flanged trappings.
- Blowdown valves.
- Non-return valves.
- Feedwater valves and regulators.
- Surface blowdown systems.

- Blend pump.
- Surge load baffles.
- Seismic design.

**Burner/Control Options:**

- Flame safeguard controllers.
- Lead/lag system.
- High altitude design.
- Special insurance and code requirements (e.g., IRI, FM, CSD-1).
- Alarm bell/silence switch.
- Special motor requirements (TEFC, high efficiency).
- Special indicating lights.
- Main disconnect.
- Elapsed time meter.
- Voltmeter/micro-ammeter.
- NEMA enclosures.
- Low-fire hold control.
- Remote emergency shut-off (115V).
- Circuit breakers.
- Day/night controls.
- Special power requirements.
- Stack thermometer.

**Fuel Options:**

- Air atomizing oil burner, 125 - 200 hp.
- Gas strainer.
- Gas pressure gauge.
- Future gas conversion.
- Oversized/undersized gas trains.

## *DIMENSIONS AND RATINGS*

Dimensions and ratings for the Model 4WG Boilers are shown in the following tables and illustrations. The information is subject to change without notice.

- Table A3-1 Model 4WG Steam Boiler Ratings
- Table A3-3 Model 4WG Hot Water Boiler Ratings
- Figure A3-1 Model 4WG Steam Boiler Dimensions
- Figure A3-2 Model 4WG Hot Water Boiler Dimensions
- Figure A3-5 Model 4WG Boiler Space Requirements to Open Rear Door
- Figure A3-6 Lifting Lug Location, Model 4WG Boilers
- Figure A3-7 Model 4WG Boiler Mounting Piers

Table A3-1. 4WG Ratings - Steam

BOILER H.P.	100	125	150	200	250	300	350	400	500	600	700	800
BURNER MODEL	FP-3	FP-3	FP-3	FP-4	FP-4	FP-4	D145P	D175P	D210P	D252P	D300P	D378P
RATINGS - SEA LEVEL TO 700 FT.												
Rated Capacity (lbs-steam/hr from and at 212 OF)	3450	4313	5175	6900	8625	10350	12075	13800	17250	20700	24150	27600
Btu Output (1000 Btu/hr)	3347	4184	5021	6694	8368	10042	11715	13389	16736	20083	23430	26778
APPROXIMATE FUEL CONSUMPTION AT RATED CAPACITY BASED ON NOMINAL 82% EFFICIENCY												
Light Oil gph (140,000 Btu/gal)	29.2	36.4	43.7	58.3	72.9	87.5	102.0	116.6	145.8	174.9	204.1	233.3
Gas CFH (1000 Btu)	4082	5102	6123	8164	10205	12246	14287	16328	20410	24492	28574	32656
Gas (Therm/hr)	40.8	51.0	61.2	81.6	102.0	122.5	142.9	163.3	204.1	244.9	285.7	326.6
POWER REQUIREMENTS - SEA LEVEL TO 700 FT. (60 HZ)												
Blower Motor hp	2	3	5	5	5	7-1/2	15	20	25	30	40	75
Circulating Oil Pump Motor hp (Oil only)	1/3*	3/4*	3/4*	1/2	1/2	3/4	3/4	3/4	3/4	3/4	1	1
Oil Metering Pump Motor hp (Oil only)	-	-	-	-	-	-	-	1/2	3/4	3/4	3/4	1
Integral Oil/Air Motor hp (Oil only)	-	-	-	-	-	-	2	-	-	-	-	-
Air Compressor Motor hp (Oil only)	**	**	**	3	3	3	-	5	5	7-1/2	7-1/2	15
BOILER DATA												
Heating Surface sq.-ft. (Fireside)	500	625	750	1000	1250	1500	1750	2000	2500	3000	3500	See Note "B"

\* Base rail mounted oil pump will be 3-phase voltage.

\*\* No air compressor required (pressure atomized).

NOTES:

A. All fractional hp motors will be single phase voltage except oil metering pump motor(3-phase); integral hp motors will be 3-phase voltage.

B. 800 hp boilers are available w/ 3500 or 4000 sq. ft. of heating surface

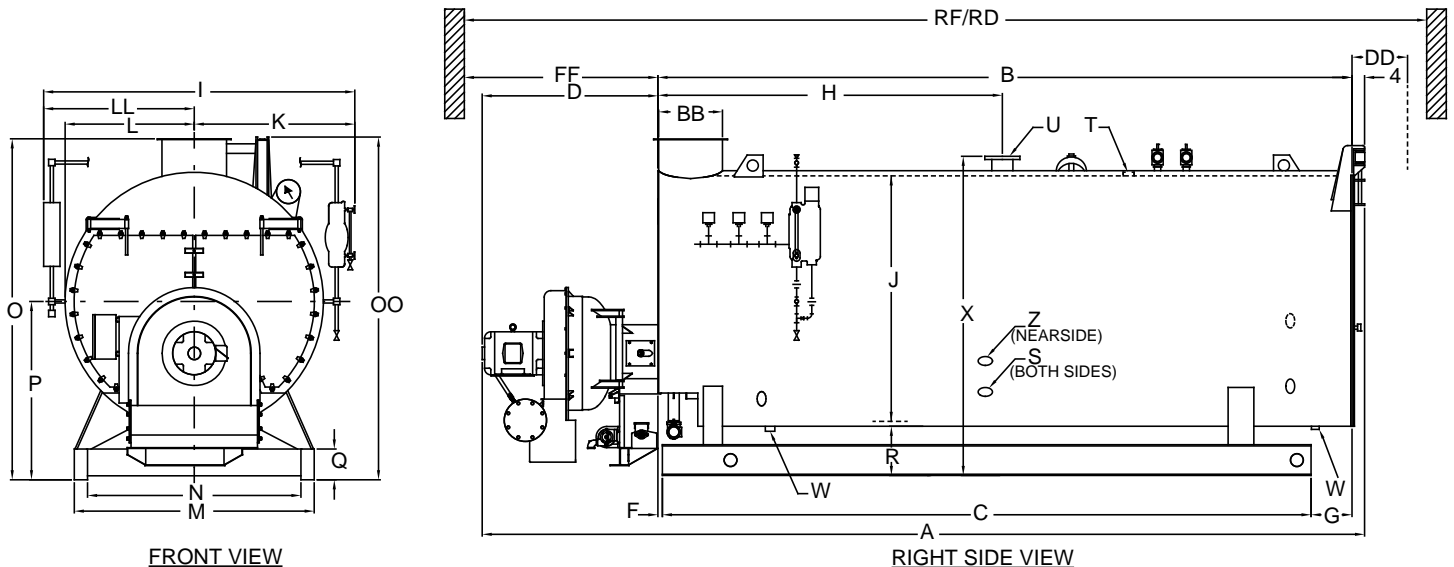

Figure A3-1. 4WG - Steam 100-800 HP

Table A3-2. 4WG Dimensions - Steam

BOILER H.P.	DIM	100	125	150	200	250	300	350	400	500	600	700	800	*800
LENGTHS														
														See Note "C"
Overall Length	A	174	198	186	227.5	220.3	244.3	245.3	263.3	276.8	311.8	296.5	304	331
Shell	B	131	155	143	177	172.5	196.5	189.8	207.8	213.8	248.8	232.8	232.8	259.8
Base Frame	C	110	124	122	156	150.12	174.13	167.25	185.25	188.25	223.75	207.25	207.25	234.75
Burner Extension	D	39	39	39	46.5	43.75	43.75	51.5	51.5	59	59	59.75	67.25	67.25
Smokebox to Base	F	0.5	0.5	0.5	0.5	0.5	0.5	0.5	0.5	0.5	0.5	0.5	0.5	0.5
Rear Ring Flange to Base	G	20.5	20.5	20.5	20.5	22	22	22	22	25	25	25	25	25
Smokebox to Steam Nozzle	H	50.88	74.88	63.88	97.88	86.25	110.3	95.63	113.6	106	141	115.6	115.6	142.6
WIDTHS														
Overall Width	I	85	85	92	92	103	103	110	110	123	123	133	133	133
I.D. Boiler	J	60	60	67	67	78	78	85	85	96	96	106	106	106
Center to Water Column	K	45	45	48.5	48.5	54	54	57.5	57.5	64	64	69	69	69
Center to Lagging	L	33	33	36.75	36.75	42	42	45.5	45.5	51	51	56	56	56
Center to Auxiliary LWCO	LL	40	40	43.5	43.5	49	49	52.5	52.5	59	59	64	64	64
Base Outside	M	52.5	52.5	51	51	64	64	60	60	71.88	71.88	74.75	74.75	74.75
Base Inside	N	44.5	44.5	43	43	56	56	47	47	58.88	58.88	61.75	61.75	61.75
HEIGHTS														
Base to Rear Davit	OO	86.12	86.12	92.75	92.75	98.88	98.88	112.8	112.8	125.1	125.1	134.3	134.3	134.3
Base to Vent Outlet	O	85	85	92.63	92.63	106	106	115	115	126	126	135.6	135.6	135.6
Base to Boiler Centerline	P	46	46	50	50	56	56	61	61	67	67	71	71	71
Height of Base Frame	Q	12	12	12	12	12	12	12	12	12	12	12	12	12
Base to Bottom of Boiler	R	15.63	15.63	16.13	16.13	16.5	16.5	18	18	18.5	18.5	17.5	17.5	17.5
Base to Steam Outlet	X	82.38	82.38	89.88	89.88	101.5	101.5	110	110	121.5	121.5	130.5	130.5	130.5
BOILER CONNECTIONS														
Feedwater Inlet (Both Sides)	S	1.25	1.5	1.5	2	2	2	2.5	2.5	2.5	2.5	2.5	2.5	2.5
Surface Blowoff (150 lb only)	T	1	1	1	1	1	1	1	1	1	1	1	1	1
Steam Nozzle 15 lb (See Note "A")	U	8	8	8	10	10	12	12	12	12	12	12	12	12
Steam Nozzle 150 lb (See Note "B")	U	4	4	4	4	6	6	6	6	8	8	8	8	8
Blowdown-Front & Rear (15 lb)	W	1.5	1.5	1.5	2	2	2	2	2	2	2	2	2	2
Blowdown-Front & Rear (15 lb)	W	1.25	1.5	1.5	1.5	1.5	1.5	1.5	2	2	2	2	2	2
Chemical Feed	Z	1	1	1	1	1	1	1	1	1	1	1	1	1
VENT STACK														
Vent Stack Diameter (Flanged)	BB	16	16	16	16	20	20	24	24	24	24	24	24	24
MINIMUM CLEARANCES														
Rear Door Swing	DD	36	36	40	40	46	46	50	50	55	55	60	60	60
Tube Removal - Front Only	FF	96	120	108	142	132.5	156.5	148	166	169	204	188	188	215
MINIMUM BOILER ROOM LENGTH ALLOWING FOR DOOR SWING AND TUBE REMOVAL FROM:														
Thru Window or Door	RD	234	258	261	295	307.5	331.5	337	355	377	412	411	411	438
Front of Boiler	RF	263	311	291	359	351	399	388	424	438	508	481	481	535
WEIGHTS IN LBS														
Normal Water Weight	-	5870	7310	7625	9995	12590	14850	16025	17950	21050	25350	28700	28700	32770
Approx. Shipping Weight – (15 psig)	-	10860	12080	13090	15260	19110	21050	24760	27640	33295	38150	42320	42320	46300
Approx. Shipping Weight – (150 psig)	-	11320	12920	13980	16620	21620	23970	26850	29650	36190	39560	46290	46290	50830

NOTES:

Accompanying dimensions, while sufficiently accurate for layout purposes, must be confirmed for construction by certified dimension diagram/drawing. All Connections are Threaded Unless Otherwise Indicated:

NOTE "A": ANSI 150 psig Flange

NOTE "B": ANSI 300 psig Flange

NOTE "C": \*800 hp w/ 4000 sq. ft. of heating surface





Table A3-4. 4WG Dimensions - Hot Water

BOILER H.P.	DIM	100	125	150	200	250	300	350	400	500	600	700	800	*800 See Note "C"
LENGTHS														
Overall Length	A	174	198	186	227.5	220.25	244.25	245.25	263.25	276.75	311.75	296.5	304	331
Shell	B	131	155	143	177	172.5	196.5	189.75	207.75	213.75	248.75	232.75	232.75	259.75
Base Frame	C	110	124	122	156	150.125	174.125	167.25	185.25	188.25	223.25	207.25	207.25	234.25
Burner Extension	D	39	39	39	46.5	43.75	43.75	51.5	51.5	59	59	59.75	67.25	67.25
Smokebox to Base	F	0.5	0.5	0.5	0.5	0.5	0.5	0.5	0.5	0.5	0.5	0.5	0.5	0.5
Rear Ring Flange to Base	G	20.5	20.5	20.5	20.5	22	22	22	22	25	25	25	25	25
Smokebox to Return	H	78	99	87	121	113.5	137.5	130.75	148.75	143	151.75	146.25	146.75	173.75
Smokebox to Outlet	HH	103	124	112	146	139.5	163.5	156.75	174.75	179	187.75	182.25	182.75	209.75
WIDTHS														
Overall Width	I	70	70	77.5	77.5	88	88	95	95	106	106	116	116	116
I.D. Boiler	J	60	60	67	67	78	78	85	85	96	96	106	106	106
Center to LWCO Controller	K	37	37	40.75	40.75	46	46	49.5	49.5	55	55	60	60	60
Center to Lagging	L	33	33	36.75	36.75	42	42	45.5	45.5	51	51	56	56	56
Base Outside	M	52.5	52.5	51	51	64	64	60	60	71.88	71.88	74.75	74.75	74.75
Base Inside	N	44.5	44.5	43	43	56	56	47	47	58.88	58.88	61.75	61.75	61.75
HEIGHTS														
Base to Rear Davit	OO	86.12	86.12	92.75	92.75	98.88	98.88	112.75	112.75	125.12	125.12	134.25	134.25	134.25
Base to Vent Outlet	O	87	87	92.63	92.63	106	106	115	115	126	126	135.63	135.63	135.63
Base to Boiler Centerline	P	46	46	50	50	56	56	61	61	67	67	71	71	71
Height of Base Frame	Q	12	12	12	12	12	12	12	12	12	12	12	12	12
Base to Bottom of Boiler	R	15.63	15.63	16.13	16.13	16.5	16.5	18	18	18.5	18.5	17.5	17.5	17.5
Base to Return & Outlet	X	82.38	82.38	89.88	89.88	101.5	101.5	110	110	121.5	121.5	130.5	130.5	130.5
BOILER CONNECTIONS														
Water Return (See Note "A")	T	4	6	6	6	8	8	8	10	10	12	12	12	12
Water Outlet (See Notes "A & B")	U	4	6	6	6	8	8	8	10	10	12	12	12	12
Drain-Front & Rear	W	1.5	1.5	1.5	2	2	2	2	2	2	2	2	2	2
Air Vent	Y	1.5	1.5	1.5	1.5	1.5	1.5	1.5	2	2	2	2	2	2
VENT STACK														
Vent Stack Diameter (Flanged)	BB	16	16	16	16	20	20	24	24	24	24	24	24	24
MINIMUM CLEARANCES														
Rear Door Swing	DD	36	36	40	40	46	46	50	50	55	55	60	60	60
Tube Removal - Front Only	FF	96	120	108	142	132.5	156.5	148	166	169	204	188	188	215
MINIMUM BOILER ROOM LENGTH ALLOWING FOR DOOR SWING AND TUBE REMOVAL FROM:														
Thru Window or Door	RD	234	258	261	295	307.5	331.5	337	355	377	412	411	411	438
Front of Boiler	RF	263	311	291	359	351	399	388	424	438	508	481	481	535
WEIGHTS IN LBS														
Normal Water Weight	-	6,890	8,580	8,870	11,600	14,760	17,380	19,220	21,520	26,260	31,580	35,900	35,900	40,930
Approx. Shipping Weight - (30 psig)	-	10,860	12,080	13,090	15,260	19,110	21,050	24,760	27,640	33,295	38,150	42,320	42,320	46,300
Approx. Shipping Weight - (125 psig)	-	11,600	12,980	14,040	16,680	20,670	23,140	26,930	30,060	35,390	40,550	45,430	45,430	49,750

NOTES:  
 Accompanying dimensions, while sufficiently accurate for layout purposes, must be confirmed for construction by certified dimension diagram/drawing. All Connections are Threaded Unless Otherwise Indicated.  
 NOTE "A": ANSI 150 psig Flange  
 NOTE "B": Water Outlet includes 2" Dip Tube  
 NOTE "C": \*800 hp w/ 4000 sq. ft. of heating surface



Table A3-5. 4WG Low NOx Ratings - Steam

BOILER H.P.	100	125	150	200	250	300	350	400	500	600	700	800
BURNER MODEL	LND54S	LND63P	LND84P	LND105P	LND145S	LND145P	LND175P	LND210P	LND252P	LND300P	LND378P	LND420P
RATINGS - SEA LEVEL TO 700 FT.												
Rated Capacity (lbs-steam/hr from and at 212 °F)	3450	4313	5175	6900	8625	10350	12075	13800	17250	20700	24150	27600
Btu Output (1000 Btu/hr)	3347	4184	5021	6694	8368	10042	11715	13389	16736	20083	23430	26778
APPROXIMATE FUEL CONSUMPTION AT RATED CAPACITY BASED ON NOMINAL 82% EFFICIENCY												
Light Oil gph (140,000 Btu/gal)	29.2	36.4	43.7	58.3	72.9	87.5	102	116.6	145.8	174.9	204.1	233.3
Gas CFH (1000 Btu)	4082	5102	6123	8164	10205	12246	14287	16328	20410	24492	28574	32656
Gas (Therm/hr)	40.8	51	61.2	81.6	102	122.5	142.9	163.3	204.1	244.9	285.7	326.6
POWER REQUIREMENTS - SEA LEVEL TO 700 FT. (60 HZ)												
Blower Motor hp	3	5	7-1/2	10	15	15	20	25	30	40	75	75
Circulating Oil Pump Motor hp (Oil only)	1/2	1/2	1/2	1/2	1/2	3/4	3/4	3/4	3/4	3/4	1	1
Oil Metering Pump Motor hp (Oil only)	-	-	-	-	-	-	1/2	1/2	3/4	3/4	1	1
Integral Oil/Air Motor hp (Oil only)	1	1	1	1	2	2	-	-	-	-	-	-
Air Compressor Motor hp (Oil only)	-	-	-	-	-	-	5	5	5	7-1/2	15	15
BOILER DATA												
Heating Surface sq-ft. (Fireside)	500	625	750	1000	1250	1500	1750	2000	2500	3000	3500	See Note "B"

NOTES:

A. All fractional hp motors will be single phase voltage except oil metering pump motor (3-phase); integral hp motors will be 3-phase voltage.

B. 800 hp boilers are available w/ 3500 or 4000 sq. ft. of heating surface

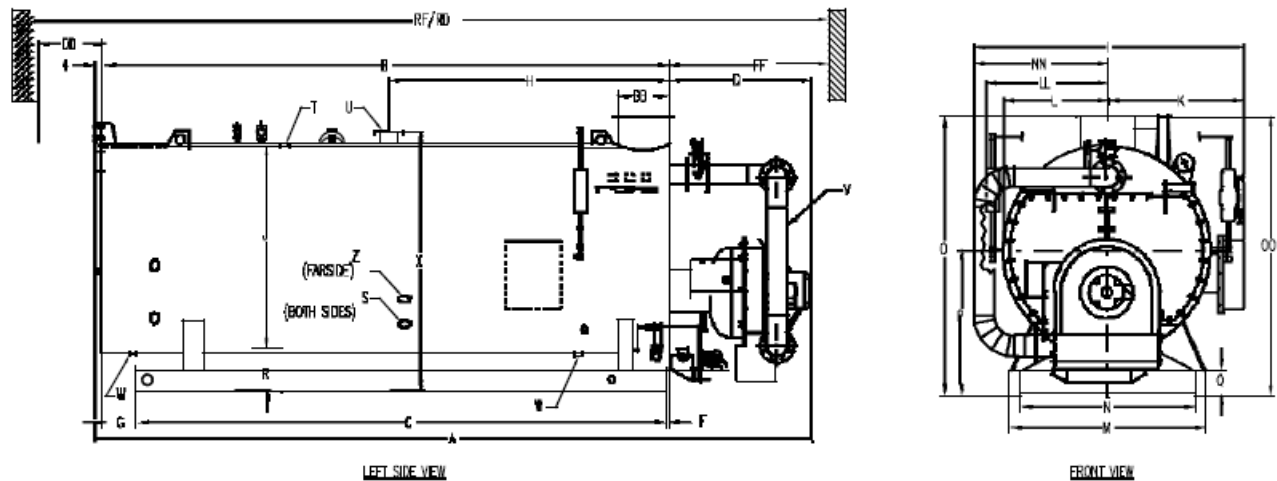

Figure A3-3. 4WG Low NOx - Steam 100-800 HP

Table A3-6. 4WG Low NOx Dimensions - Steam

BOILER H.P.	DIM	100	125	150	200	250	300	350	400	500	600	700/800	*800
LENGTHS													See Note "C"
Overall Length	A	176	200	189.6	223.6	229.6	253.6	250	270.6	276.6	311.6	304	331
Shell	B	131	155	143	177	172.5	196.5	189.8	207.8	213.8	248.8	232.8	259.8
Base Frame	C	110	124	122	156	150.13	174.13	167.25	185.25	188.25	223.25	207.25	234.25
Burner Extension	D	41	41	42.62	42.62	53.12	53.12	56.25	58.88	58.88	58.88	67.25	67.25
Smokebox to Base	F	0.5	0.5	0.5	0.5	0.5	0.5	0.5	0.5	0.5	0.5	0.5	0.5
Rear Ring Flange to Base	G	20.5	20.5	20.5	20.5	22	22	22	22	25	25	25	25
Smokebox to Steam Nozzle	H	50.88	74.88	63.88	97.88	86.25	110.3	95.63	113.6	106	141	115.6	142.6
WIDTHS													
Overall Width	I	90.5	85	92	92	103	103	110	110	125	126	133	133
I.D. Boiler	J	60	60	67	67	78	78	85	85	96	96	106	106
Center to Water Column	K	45	45	48.5	48.5	54	54	57.5	57.5	64	64	69	69
Center to Lagging	L	33	33	36.75	36.75	42	42	45.5	45.5	51	51	56	56
Center to Auxiliary LWCO	LL	40	40	43.5	43.5	49	49	52.5	52.5	59	59	64	64
Base Outside	M	52.5	52.5	51	51	64	64	60	60	71.88	71.88	74.75	74.75
Base Inside	N	44.5	44.5	43	43	56	56	47	47	58.88	58.88	61.75	61.75
Center to Outside of FGR Duct	NN	45.5	39.5	39.5	39.5	43.5	43.5	49.75	49.75	61	62	62.5	62.5
FGR Duct Size	V	6	6	6	6	6	8	8	8	8	10	10	10
HEIGHTS													
Base to Rear Davit	OO	86.12	86.12	92.75	92.75	98.88	98.88	112.8	112.8	125.1	125.1	134.3	134.3
Base to Vent Outlet	O	85	85	92.63	92.63	106	106	115	115	126	126	135.6	135.6
Base to Boiler Centerline	P	46	46	50	50	56	56	61	61	67	67	71	71
Height of Base Frame	Q	12	12	12	12	12	12	12	12	12	12	12	12
Base to Bottom of Boiler	R	15.63	15.63	16.13	16.13	16.5	16.5	18	18	18.5	18.5	17.5	17.5
Base to Steam Outlet	X	82.38	82.38	89.88	89.88	101.5	101.5	110	110	121.5	121.5	130.5	130.5
BOILER CONNECTIONS													
Feedwater Inlet (Both Sides)	S	1.25	1.5	1.5	2	2	2	2.5	2.5	2.5	2.5	2.5	2.5
Surface Blowoff (150 lb only)	T	1	1	1	1	1	1	1	1	1	1	1	1
Steam Nozzle 15 lb (See Note "A")	U	8	8	8	10	10	12	12	12	12	12	12	12
Steam Nozzle 150 lb (See Note "B")	U	4	4	4	4	6	6	6	6	8	8	8	8
Blowdown-Front & Rear (15 lb)	W	1.5	1.5	1.5	2	2	2	2	2	2	2	2	2
Blowdown-Front & Rear (150 lb)	W	1.25	1.5	1.5	1.5	1.5	1.5	1.5	2	2	2	2	2
Chemical Feed	Z	1	1	1	1	1	1	1	1	1	1	1	1
VENT STACK													
Vent Stack Diameter (Flanged)	BB	16	16	16	16	20	20	24	24	24	24	24	24
MINIMUM CLEARANCES													
Rear Door Swing	DD	36	36	40	40	46	46	50	50	55	55	60	60
Tube Removal - Front Only	FF	96	120	108	142	132.5	156.5	148	166	169	204	188	215
MINIMUM BOILER ROOM LENGTH ALLOWING FOR DOOR SWING AND TUBE REMOVAL FROM:													
Thru Window or Door	RD	234	258	261	295	307.5	331.5	337	355	377	412	411	438
Front of Boiler	RF	263	311	291	359	351	399	388	424	438	508	481	535
WEIGHTS IN LBS													
Normal Water Weight	-	5,870	7,310	7,625	9,995	12,590	14,850	16,025	17,950	21,050	25,350	28,700	32,770
Approx. Shipping Weight - (15 psig)	-	10,860	12,080	13,090	15,260	19,110	21,050	24,760	27,640	33,295	38,150	42,320	46,300
Approx. Shipping Weight - (150 psig)	-	11,320	12,920	13,980	16,620	21,620	23,970	26,850	29,650	36,190	39,560	46,290	50,830

NOTES:

Accompanying dimensions, while sufficiently accurate for layout purposes, must be confirmed for construction by certified dimension diagram/drawing. All Connections are Threaded Unless Otherwise Indicated:

NOTE "A": ANSI 150 psig Flange

NOTE "B": ANSI 300 psig Flange

NOTE "C": \*800 hp w/ 4000 sq. ft. of heating surface



Table A3-7. 4WG Low NOx Ratings - Hot Water

BOILER H.P.	100	125	150	200	250	300	350	400	500	600	700	800
BURNER MODEL	LND54S	LND63P	LND84P	LND105P	LND145S	LND145P	LND175P	LND210P	LND252P	LND300P	LND378P	LND420P
RATINGS - SEA LEVEL TO 700 FT.												
Btu Output (1000 Btu/hr)	3347	4184	5021	6694	8368	10042	11715	13389	16736	20083	23430	26778
APPROXIMATE FUEL CONSUMPTION AT RATED CAPACITY BASED ON NOMINAL 82% EFFICIENCY												
Light Oil gph (140,000 Btu/gal)	29.2	36.4	43.7	58.3	72.9	87.5	102.0	116.6	145.8	174.9	204.1	233.3
Gas CFH (1000 Btu)	4082	5102	6123	8164	10205	12246	14287	16328	20410	24492	28574	32656
Gas (Therm/hr)	40.8	51.0	61.2	81.6	102.0	122.5	142.9	163.3	204.1	244.9	285.7	326.6
POWER REQUIREMENTS - SEA LEVEL TO 700 FT. (60 HZ)												
Blower Motor hp	3	5	7-1/2	10	15	15	20	25	30	40	75	75
Circulating Oil Pump Motor hp (Oil only)	1/2	1/2	1/2	1/2	1/2	3/4	3/4	3/4	3/4	3/4	1	1
Oil Metering Pump Motor hp (Oil only)	-	-	-	-	-	-	1/2	1/2	3/4	3/4	1	1
Integral Oil/Air Motor hp (Oil only)	1	1	1	1	2	2	-	-	-	-	-	-
Air Compressor Motor hp (Oil only)	-	-	-	-	-	-	5	5	5	7-1/2	15	15
BOILER DATA												
Heating Surface sq-ft. (Fireside)	500	625	750	1000	1250	1500	1750	2000	2500	3000	3500	See Note "B"

NOTES:  
 A. All fractional hp motors will be single phase voltage except oil metering pump motor(3-phase); integral hp motors will be 3-phase voltage.  
 B. 800 hp boilers are available w 3500 or 4000 sq. ft. of heating surface

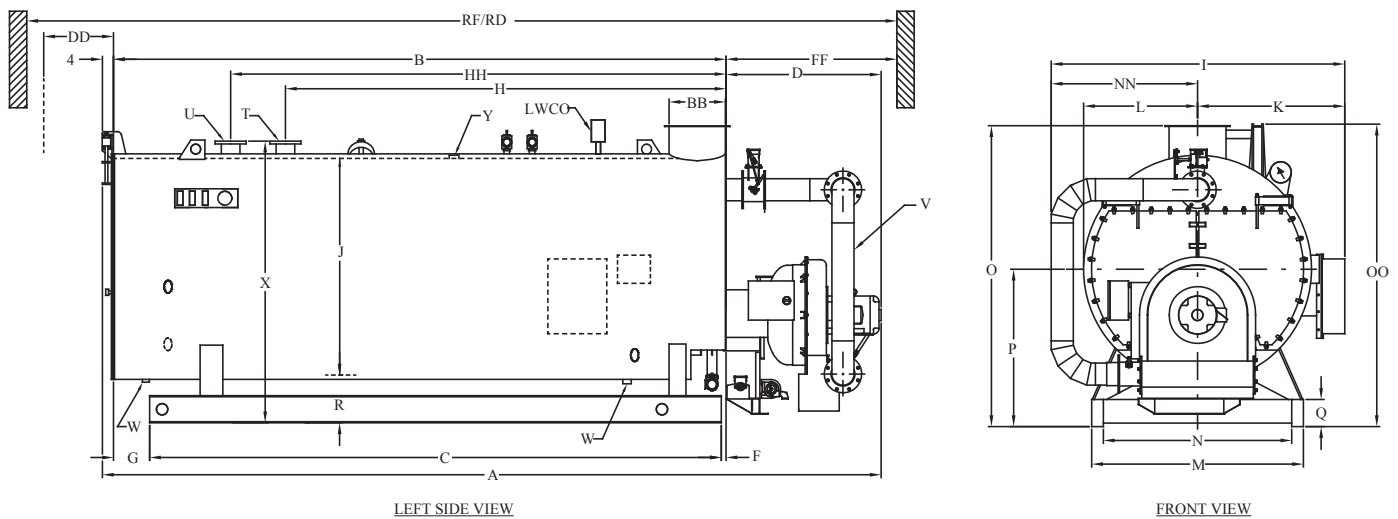

Figure A3-4. 4WG Low NOx - Hot Water 100-800 HP

Table A3-8. 4WG Low NOx Dimensions - Hot Water

BOILER H.P.	DIM	100	125	150	200	250	300	350	400	500	600	700/800	*800 See Note "C"
<b>LENGTHS</b>													
Overall Length	A	176	200	189.62	223.62	229.62	253.62	250	270.63	276.63	311.63	304	331
Shell	B	131	155	143	177	172.5	196.5	189.75	207.75	213.75	248.75	232.75	259.75
Base Frame	C	110	124	122	156	150.13	174.13	167.25	185.25	188.25	223.25	207.25	234.25
Burner Extension	D	41	41	42.62	42.62	53.12	53.12	56.25	58.88	58.88	58.88	67.25	67.25
Smokebox to Base	F	0.5	0.5	0.5	0.5	0.5	0.5	0.5	0.5	0.5	0.5	0.5	0.5
Rear Ring Flange to Base	G	20.5	20.5	20.5	20.5	22	22	22	22	25	25	25	25
Smokebox to Return	H	78	99	87	121	113.5	137.5	130.75	148.75	143	151.75	146.75	173.75
Smokebox to Outlet	HH	103	124	112	146	139.5	163.5	156.75	174.75	179	187.75	182.75	209.75
<b>WIDTHS</b>													
Overall Width	I	82.5	76.5	80.25	80.25	89.5	89.5	99.25	99.25	116	117	122.5	122.5
I.D. Boiler	J	60	60	67	67	78	78	85	85	96	96	106	106
Center to LWCO Controller	K	37	37	40.75	40.75	46	46	49.5	49.5	55	55	60	60
Center to Lagging	L	33	33	36.75	36.75	42	42	45.5	45.5	51	51	56	56
Base Outside	M	52.5	52.5	51	51	64	64	60	60	71.88	71.88	74.75	74.75
Base Inside	N	44.5	44.5	43	43	56	56	47	47	58.88	58.88	61.75	61.75
Center to Outside of FGR Duct	NN	45.5	39.5	39.5	39.5	43.5	43.5	49.75	49.75	61	62	62.5	62.5
FGR Duct Size	V	6	6	6	6	6	8	8	8	8	10	10	10
<b>HEIGHTS</b>													
Base to Rear Davit	OO	86.12	86.12	92.75	92.75	98.88	98.88	112.75	112.75	125.12	125.12	134.25	134.25
Base to Vent Outlet	O	87	87	89.88	89.88	106	106	115	115	126	126	135.63	135.63
Base to Boiler Centerline	P	46	46	50	50	56	56	61	61	67	67	71	71
Height of Base Frame	Q	12	12	12	12	12	12	12	12	12	12	12	12
Base to Bottom of Boiler	R	15.63	15.63	16.13	16.13	16.5	16.5	18	18	18.5	18.5	17.5	17.5
Base to Return & Outlet	X	82.38	82.38	92.63	92.63	101.5	101.5	110	110	121.5	121.5	130.5	130.5
<b>BOILER CONNECTIONS</b>													
Water Return (See Note "A")	T	4	6	6	6	8	8	8	10	10	12	12	12
Water Outlet (See Notes "A & B")	U	4	6	6	6	8	8	8	10	10	12	12	12
Drain-Front & Rear	W	1.5	1.5	1.5	2	2	2	2	2	2	2	2	2
Air Vent	Y	1.5	1.5	1.5	1.5	1.5	1.5	1.5	2	2	2	2	2
<b>VENT STACK</b>													
Vent Stack Diameter (Flanged)	BB	16	16	16	16	20	20	24	24	24	24	24	24
<b>MINIMUM CLEARANCES</b>													
Rear Door Swing	DD	36	36	40	40	46	46	50	50	55	55	60	60
Tube Removal - Front Only	FF	96	120	108	142	132.5	156.5	148	166	169	204	188	215
<b>MINIMUM BOILER ROOM LENGTH ALLOWING FOR DOOR SWING AND TUBE REMOVAL FROM:</b>													
Thru Window or Door	RD	234	258	261	295	307.5	331.5	337	355	377	412	411	438
Front of Boiler	RF	263	311	291	359	351	399	388	424	438	508	481	535
<b>WEIGHTS IN LBS</b>													
Normal Water Weight	-	6,890	8,580	8,870	11,600	14,760	17,380	19,220	21,520	26,260	31,580	35,900	40,930
Approx. Shipping Weight - (30psig)	-	10,860	12,080	13,090	15,260	19,110	21,050	24,760	27,640	33,295	38,150	42,320	46,300
Approx. Shipping Weight - (125psig)	-	11,600	12,980	14,040	16,680	20,670	23,140	26,930	30,060	35,390	40,550	45,430	49,750

NOTES:

Accompanying dimensions, while sufficiently accurate for layout purposes, must be confirmed for construction by certified dimension diagram/drawing. All Connections are Threaded Unless Otherwise Indicated:

NOTE "A": ANSI 150 psig Flange

NOTE "B": Water Outlet includes 2" Dip Tube

NOTE "C": \*800 hp w/ 4000 sq. ft. of heating surface



BOILER HP	ALL DIMENSIONS IN INCHES				
	A	B	C	D	E
100-125	33	47	52	80	36
150-200	36.5	49	56	83	40
250-300	42	56	61	92	46
350-400	45.5	58	68	99	50
500-600	51	66	75	111	55
700-800	56	74	80	121	60

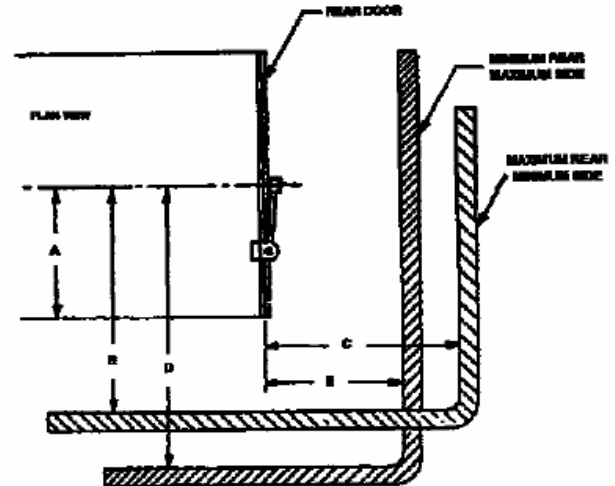
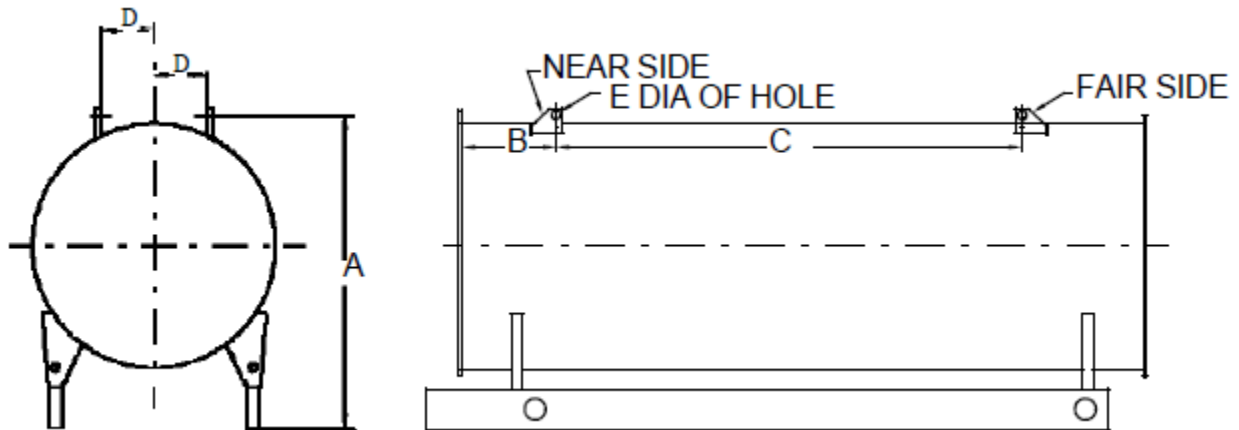

Figure A3-5. Space Required to Open Rear Head on Model 4WG



BOILER HP	ALL DIMENSIONS IN INCHES				
	A	B	C	D	E
100	79.5	21.375	84.75	10	3
125	79.5	21.375	108.75	10	3
150	87.125	21.375	96.75	10	3
200	87.125	21.375	130.75	10	3
250	99	28.75	104.25	10	3
300	99	28.75	128.25	10	3
350	107.625	33.25	126	10	3
400	107.625	33.25	144	10	3
500	125.375	34.5	145	10	3
600	125.375	34.5	180	10	3
700-800	134.5	34.5	164	10	3

NOTE: A, B, and C dimensions may vary by 1 inch.

Figure A3-6. Model 4WG Lift Lug Locations

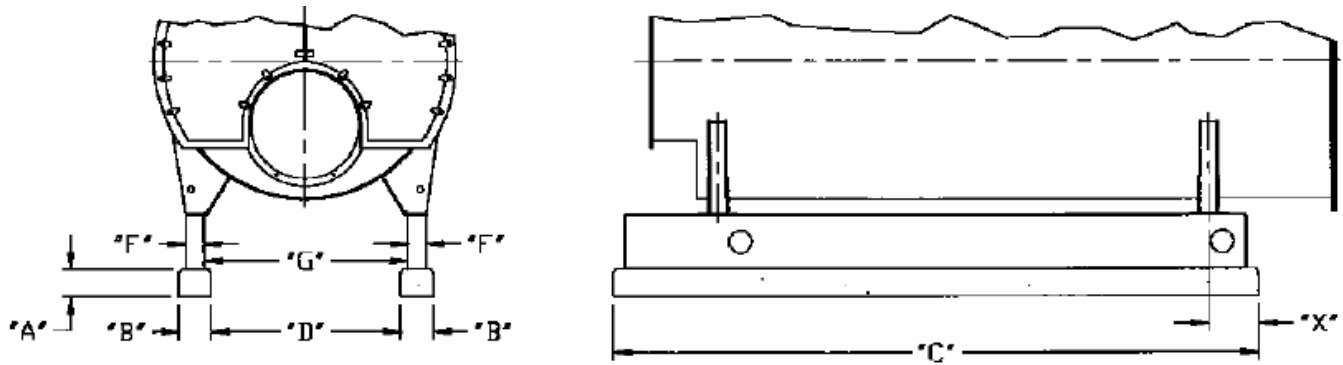

BOILER HP	ALL DIMENSIONS IN INCHES							
	A	B	C	D	E	F	G	X
100	6	9	110	39.5	57.5	4	44.5	8
125	6	9	124	39.5	57.5	4	44.5	8
150	6	9	122	38	56	4	43	8
200	6	9	156	38	56	4	43	8
250	6	9	150.125	51	69	4	56	11.5
300	6	9	174.125	51	69	4	56	11.5
350	6	12	167.25	41.5	65.5	6.5	47	11.5
400	6	12	185.25	41.5	65.5	6.5	47	11.5
500	6	12	188.25	53.375	77.375	6.5	58.875	10.5
600	6	12	223.25	53.375	77.375	6.5	58.875	10.5
700-800	6	12	207.25	56.25	80.25	6.5	61.75	10.5

NOTE:

6-inch high mounting piers recommended for use beneath the boiler base frame. The use of these piers provides increased inspection accessibility to the boiler and added height for washing down the area beneath the boiler.

**Figure A3-7. Model 4WG Mounting Piers**

**PERFORMANCE DATA**

Contact your local Cleaver-Brooks authorized representative for efficiencies.

Cleaver-Brooks 4WG boilers are available with the standard burner package, or optional model Profire LE or Profire NT if NOx reductions of between 75 and <9 PPM on natural gas are required, or 70 PPM on #2 oil with 0.02% fuel bound nitrogen.

## ENGINEERING DATA

The following engineering information is provided for Model 4WG Boilers. Additional detail is available from your local Cleaver-Brooks authorized representative.

### Boiler Information

- Table A3-11 shows steam volume and disengaging area for model 4WG boilers.
- Table A3-12 lists quantity and outlet size for safety valves supplied on Model 4WG steam boilers.
- Table A3-13 lists quantity and outlet size for relief valves supplied on Model 4WG hot water boilers.
- Table A3-14 gives recommended steam nozzle sizes on Model 4WG Boilers.
- Table A3-15 shows recommended non-return valve sizes for Model 4WG Boilers.

### Blowdown Water Requirements

Some local codes require blowdown tanks to be constructed in accordance with recommendations of the National Board of Boiler and Pressure Vessel Inspectors.

The National Board's recommendations base the size of the blowdown tank on the removal of at least 4 inches of water from the boiler.

Table A3-9 lists the approximate quantity of water represented by 4 inches of water at normal operating level for Cleaver-Brooks Model 4WG Boilers.

## Burner/Control Information

### Burner Characteristics

Maximum altitude for standard burners is shown in Table A3-16. Note that altitude correction and burner changes are required for higher altitudes which may alter dimensions, motor hp and gas pressures.

### Gas-Fired Burners

Table A3-16 shows correction factors for gas pressure at elevations over 700 ft. above sea level.

Table A3-17 shows minimum and maximum gas pressure requirements for Standard, FM and IRI 4WG Boiler gas trains upstream of the gas pressure regulator.

For oversized or undersized gas trains or altitude above 2,000 feet, contact your local Cleaver-Brooks authorized representative.

### Fuel Connections - Gas

The local gas company should be consulted for requirements and authorization for installation and inspection of gas supply piping. Installation of gas supply piping and venting must be in accordance with all applicable engineering guidelines and regulatory codes. All connections made to the boiler should be arranged so that all components remain accessible for inspection, cleaning and maintenance.

A drip leg should be installed in the supply piping before the connection to the gas pressure regulator. The drip leg should be at least as large as the inlet fitting supplied with the boiler. Consideration must be given to both volume and pressure requirements when choosing gas supply piping size. Refer to the boiler dimension diagram provided by Cleaver-Brooks for the particular installation. Connections to the burner gas train should be made with a union, so that gas train components or the burner may be easily disconnected for inspection or service. Upon completion of the gas piping installation, the system should be checked for gas leakage and tight shutoff of all valves.

### Fuel Connections - Oil

Oil-fired burners are equipped with an oil pump, which draws fuel from a storage tank and supplies pressurized oil to the burner nozzle(s). The burner supply oil pump has a greater capacity than the burner requires for the maximum firing rate. Fuel not delivered to the nozzle is returned to the storage tank. A two-pipe (supply and return) oil system is recommended for all installations. Figure A3-8 shows a typical fuel oil supply arrangement. Oil lines must be sized for the burner and burner supply oil pump capacities.

The burner supply oil pump suction should not exceed 10" Hg. If a transfer pump is used, it must have a pumping capacity at least equal to that of the burner pump(s). Supply pressure to the burner pump should not exceed 3 psig.

A strainer must be installed in the supply piping upstream of the burner supply pump in order to prevent entry of foreign material into the pump, fuel control valves, or burner nozzle(s). The strainer must be sized for the burner supply pump capacity. A strainer mesh of 150 microns (0.005") is recommended.

Install a check valve in the line to prevent draining of the oil suction line when the burner is not in operation. Location of the check valve varies with the system, but usually it is located as close as possible to the storage tank.

Installation of a vacuum gauge in the burner supply line between the burner oil pump and the strainer is recommended. Regular observation and recording of the gauge indication will assist in determining when the strainer needs servicing.

Upon completion of the oil piping installation, the system should be checked for oil or air leakage and tight shutoff of all valves.

### Boiler Room Information

Figure A3-9 shows typical boiler room length requirements.

Figure A3-10 shows typical boiler room width requirements.

### Stack Support Capabilities

100- 800 hp Model 4WG Boilers can support up to 2000 lbs without additional support.

100 - 800 hp Model 4WG Boilers can be reinforced to support up to 3000 lbs.

### Boiler Room Combustion Air

When determining boiler room air requirements, the size of the room, air flow, and velocity of air must be reviewed as follows:

1. Size (area) and location of air supply openings in boiler room.
  - A. Two (2) permanent air supply openings in the outer walls of the boiler room are recommended. Locate one (1) at each end of the boiler room, preferably below a height of 7 feet. This allows air to sweep the length of the boiler.
  - B. Air supply openings can be louvered for weather protection, but they should not be covered with fine mesh wire, as this type of covering has poor air flow qualities and is subject to clogging by dust or dirt.
  - C. A vent fan in the boiler room is not recommended, as it could create a slight vacuum under certain conditions and cause variations in the quantity of combustion air. This can result in unsatisfactory burner performance.
  - D. Under no condition should the total area of the air supply openings be less than one (1) square foot.
  - E. Size the openings by using the formula:  $\text{Area (sq.-ft.)} = \text{CFM/FPM}$

2. Amount of air required (cfm).
  - A. Combustion Air = Rated bhp x 8 cfm/bhp.
  - B. Ventilation Air = Maximum bhp x 2 cfm/bhp or a total of 10 cfm/bhp - up to 1000 feet elevation. Add 3 percent more per 1000 feet of added elevation.
3. Acceptable air velocity in Boiler Room (fpm).
  - A. From floor to (7) foot height - 250 fpm.
  - B. Above (7) foot height - 500 fpm.

Example: Determine the area of the boiler room air supply openings for (1) 300 hp boiler at 800 feet altitude. The air openings are to be 5 feet above floor level.

- Air required:  $300 \times 10 = 3000$  cfm (from 2B above).
- Air velocity: Up to 7 feet = 250 fpm (from 3 above).
- Area Required:  $\text{Area} = \text{cfm}/\text{fpm} = 3000/250 = 12$  Sq.-ft. total.
- Area/Opening:  $12/2 = 6$  sq.-ft./opening (2 required).

### Notice

**Consult local codes, which may supersede these requirements.**

**Stack/Breeching Size Criteria**

The design of the stack and breeching must provide the required draft at each boiler flue gas outlet. Proper draft is critical to burner performance.

Although constant pressure at the flue gas outlet of the Model 4WG is not required, it is necessary to size the stack/ breeching to limit flue gas pressure variation. The allowable pressure range is -0.25" W.C. to +0.25" W.C.

For additional information, please review Section I4, General Engineering Data (Stacks) and Section F, Stacks. Stack and breeching sizes should always be provided by a reputable stack supplier who will design the stack and breeching system based on the above criteria. Your local Cleaver-Brooks authorized representative is capable of assisting in your evaluation of the stack/breeching design.

**Table A3-9. 4WG Blowdown Tank Sizing Information**

BOILER HP	WATER (GAL)
100	85
125	104
150	102
200	131
250	145
300	169
350	178
400	198
500	233
600	278
700	286
800	286

NOTE: Quantity of water removed from boiler by lowering normal water line 4".

**Table A3-10. 4WG Boilers: Predicted Sound Levels (30 ppm NOx systems) @ High Fire**

BHP	Sound Level-dBA
100	81
125	83.5
150	89.5
200	88.6
250	88.5
300	91
350	94
400	91.5
500	93.5
600	93.5
700	93.7
800	93.5

**Table A3-11. Steam Volume and Disengaging Areas**

BOILER HP	STEAM VOLUME CU-FT		STEAM RELIEVING AREA SQ-IN	
	HIGH PRESSURE	LOW PRESSURE	HIGH PRESSURE	LOW PRESSURE
	(A)	(B)	(A)	(B)
100	16.5	22.3	4565	4954
125	20.3	27.4	5587	6077
150	19.9	26.8	5443	5918
200	25.7	34.6	7013	7632
250	34.8	49.5	7790	8597
300	40.6	57.9	9115	10051
350	51.3	69.6	9734	10570
400	57.2	77.5	10843	11779
500	83.6	107.6	12874	13781
600	100	128.6	15394	16474
700	115.6	144.9	15826	16819
800	115.6	144.9	15826	16819

**NOTE:**

- 1. Based on normal water level.
- A. Based on 150 psig design pressure.
- B. Based on 15 psig design pressure.

**Table A3-12. Model 4WG Steam Boiler Safety Valve Outlet Size**

VALVE SETTING	15 PSIG STEAM		150 PSIG STEAM		200 PSIG STEAM		250 PSIG STEAM		300 PSIG STEAM	
	NO. OF VALVES REQ'D	OUTLET SIZE (IN.)	NO. OF VALVES REQ'D	OUTLET SIZE (IN.)	NO. OF VALVES REQ'D	OUTLET SIZE (IN.)	NO. OF VALVES REQ'D	OUTLET SIZE (IN.)	NO. OF VALVES REQ'D	OUTLET SIZE (IN.)
100	1	2-1/2	1	1-1/2	1	1-1/2	1	1-1/4	1	1-1/4
125	1	3	2	(1) 1-1/2 (1) 1-1/4	2	(1) 1-1/4 (1) 1	2	1	2	1
150	1	3	2	(1) 1-1/2 (1) 1-1/4	2	(1) 1 (1) 1-1/4	2	1	2	1
200	2	2-1/2	2	1-1/2	2	(1) 1-1/2 (1) 1-1/4	2	1-1/4	2	(1) 1 (1) 1-1/4
250	2	(1) 2-1/2 (1) 3	2	(1) 2 (1) 1-1/2	2	1-1/4	2	(1) 1-1/2 (1) 1-1/4	2	1-1/4
300	2	3	2	(1) 2 (1) 1-1/2	2	1-1/2	2	1-1/4	2	(1) 1-1/2 (1) 1-1/4
350	3	(1) 2 (2) 3	2	2	2	(1) 1-1/2 (1) 2	2	1-1/2	2	(1) 1-1/2 (1) 1-1/4
400	3	(2) 3 (1) 2-1/2	2	(1) 2-1/2 (1) 2	2	(1) 1-1/2 (1) 2	2	(1) 1-1/2 (1) 2	2	1-1/2
500	3	3	2	(1) 2-1/2 (1) 2	2	(1) 2-1/2 (1) 2	2	(1) 1-1/2 (1) 2	2	(1) 1-1/2 (1) 2
600	4	(3) 3 (1) 2-1/2	2	2-1/2	2	(1) 2 (1) 2-1/2	2	2	2	2
700	5	(3) 3 (2) 2-1/2	3	(2) 2-1/2 (1) 2	2	2-1/2	2	(1) 2 (1) 2-1/2	2	2
800	5	(3) 3 (2) 2-1/2	3	(2) 2-1/2 (1) 2	2	2-1/2	2	(1) 2 (1) 2-1/2	2	(1) 2 (1) 2-1/2

NOTE: Valve manufacturers are Kunkle, Consolidated or Conbraco, depending on availability. This table revised 04/2012



**Table A3-13. Model 4WG Hot Water Relief Valve Outlet Size**

VALVE SETTING	30 PSIG HW		125 PSIG HW		150 PSIG HTHW	
	NO. OF VALVES REQ'D	OUTLET SIZE (IN.)	NO. OF VALVES REQ'D	OUTLET SIZE (IN.)	NO. OF VALVES REQ'D	OUTLET SIZE (IN.)
100	1	2-1/2	1	1-1/4	1	2
125	1	2-1/2	1	1-1/4	2	(1) 1-1/2 (1) 2
150	1	2-1/2	1	2	2	(1) 1-1/2 (1) 2
200	2	(1) 2-1/2 (1) 1-1/4	1	2	2	2
250	2	(1) 2 (1) 2-1/2	1	2	2	(1) 2 (1) 2-1/2
300	2	2-1/2	1	2-1/2	2	2-1/2
350	3	(2) 2-1/2 (1) 1	1	2-1/2	2	(1) 2-1/2 (1) 3
400	3	(1) 2 (2) 2-1/2	1	2-1/2	2	(1) 2-1/2 (1) 3
500	4	(1) 1 (3) 2-1/2		(1) 1 (1) 2-1/2	2	3
600	4	(3) 2-1/2 (1) 2	2	(1) 1-1/4 (1) 2-1/2	3	(2) 3 (1) 2-1/2
700, 800	5	(1) 1 (4) 2-1/2	2	(1) 2-1/2 (1) 2	3	3

NOTE: Relief valve is Kunkle #537 for 30# & 125#(Section IV) boiler and is Kunkle #927

**Table A3-14. 4WG Recommended Steam Nozzle Size**

OPERATING PRESSURE	BOILER HP											
	100	125	150	200	250	300	350	400	500	600	700	800
PSIG												
15	8	8	8	10	10	12	12	12	12	12	12	12
30	6	6	6	8	8	8	10	10	10	12	12	12
40	6	6	6	6	8	8	8	10	10	10	12	12
50	4	6	6	6	6	8	8	8	10	10	10	12
75	4	4	4	6	6	6	8	8	8	8	10	10
100	4	4	4	6	6	6	6	6	8	8	8	10
125	4	4	4	4	6	6	6	6	8	8	8	8
150	2.5	3	3	4	4	6	6	6	6	6	8	8
200	2.5	2.5	3	4	4	4	4	6	6	6	6	6
250	2	2.5	3	3	4	4	4	4	6	6	6	6

NOTES:

1. Steam nozzle sizes given in inches.
2. Recommended steam nozzle sizes based on 4000 to 5000 fpm steam velocity.
3. All standard steam nozzle sizes for 150 psig design pressure or greater are the same as 125 psig operating pressure on the above table. To increase or decrease the standard size, request the change with your local Cleaver-Brooks authorized representative.
4. Shaded area denotes special surge load baffles must be installed to avoid possible water carryover.
5. For incremental operating pressure, see Table I3-1 Steam System Fundamentals.

**Table A3-15. 4WG Recommended Non-Return Valve Size**

BOILER HP	BOILER CAPACITY (LBS/HR)	OPERATING PRESSURE (PSIG)							
		50	75	100	125	150	175	200	250
100	3450	2-1/2	2-1/2	NA	NA	NA	NA	NA	NA
125	4313	3	2-1/2	2-1/2	2-1/2	NA	NA	NA	NA
150	5175	3	3	2-1/2	2-1/2	2-1/2	2-1/2	NA	NA
200	6900	3*	3	3	3	3	2-1/2	2-1/2	2-1/2
250	8625	4	3*	3	3	3	3	3	3
300	10350	4	4	4	3*	3	3	3	3
350	12025	4	4	4	4	4	3*	3	3
400	13800	5	4	4	4	4	4	4	3*
500	17210	6	5	5	4	4	4	4	4
600	20700	6	6	5	5	5	4	4	4
700	24150	6	6	6	5	5	5	5	4
800	27600	6	6	6	6	6	5	5	5

NOTE: Valve sizes (300 # Flanges) given in inches.

Standard Non-Return valve selections limited to a maximum 2 to 1 turndown (50% of full load); selections based on typical non-return valve sizing recommendations. For final valve selection contact your C-B authorized representative. For high turndown applications see Boiler Book Section I3, Table I3-3.

\* Indicates pressure drop of less than 7.5 psig. All other selections are less than 6 psig pressure drop.

**Table A3-16. Altitude Correction for Gas**

ALTITUDE (FT)	CORRECTION FACTOR	ALTITUDE (FT)	CORRECTION FACTOR
1000	1.04	6000	1.25
2000	1.07	7000	1.3
3000	1.11	8000	1.35
4000	1.16	9000	1.4
5000	1.21	-	-

To obtain minimum required gas pressure at altitudes above 700 feet, multiply the pressure by the listed factors:

- Inches WC x 0.577 = oz/sq-in.
- oz/sq-in x 1.732 = inches WC.
- Inches WC x 0.0361 = psig.
- oz/sq-in x 0.0625 = psig.
- psig x 27.71 = Inches WC.
- psig x 16.0 = oz/sq-in.

**Table A3-17. Model 4WG, Standard and Low NOx (30 ppm), Minimum Required Gas Pressure at Entrance to Standard, FM and IRI Gas Trains (Upstream of Gas Pressure Regulator)**

BOILER HP	STD PIPE SIZE (Inches)	PRESSURE REQUIRED-STD ("WC)			PRESSURE REQUIRED-30 PPM ("WC)		
		GPR*	Minimum	Maximum	GPR*	Minimum	Maximum
100	2	RV91	9	27.7	RV91	12.3	27.7
125	2	RV91	16.6	27.7	RV91	21.6	27.7
150	2	RV91	23.2	27.7	RV91	21.9	27.7
200	2.5	210G	20.7	277	210G	28.5	277
250	2.5	210G	29.9	277	210G	29	277
300	2.5	210G	40.8	277	210G	39.5	277
350	3	210G	42.7	277	210G	40.7	277
400	1.5-2	S	130	208	S	130	208
	2-2.5	S	89	130	S	89	130
	2.5	S	64	89	S	64	89
	3	S	39	64	S	39	64
500	1.5-2.5	S	183	277	S	175	277
	2-2.5	S	130	183	S	125	175
	2.5	S	89	130	S	83	125
	3	S	50	89	S	44	83
600	2-1.5-2.5	S	233	277	S	241	277
	2-2.5	S	177	233	S	186	241
	2.5	S	119	177	S	127	186
	2.5-3	S	100	119	S	108	127
	3	S	61	100	S	69	108
700	2-3	S	222	277	S	213	277
	2.5-3	S	133	222	S	125	213
	3	S	83	133	S	75	125
	4	S	55	83	S	44	75
800	2-3	S	255	277	S	260	277
	2.5-3	S	152	255	S	155	260
	3	S	94	152	S	94	155
	4	S	53	94	S	55	94

NOTE: Where multiple gas train sizes are shown, the shaded row indicates standard size. For altitudes above 700 feet, contact your local Cleaver-Brooks authorized representative.

\* GPR Gas Pressure Regulator

S-Siemens regulating actuator.



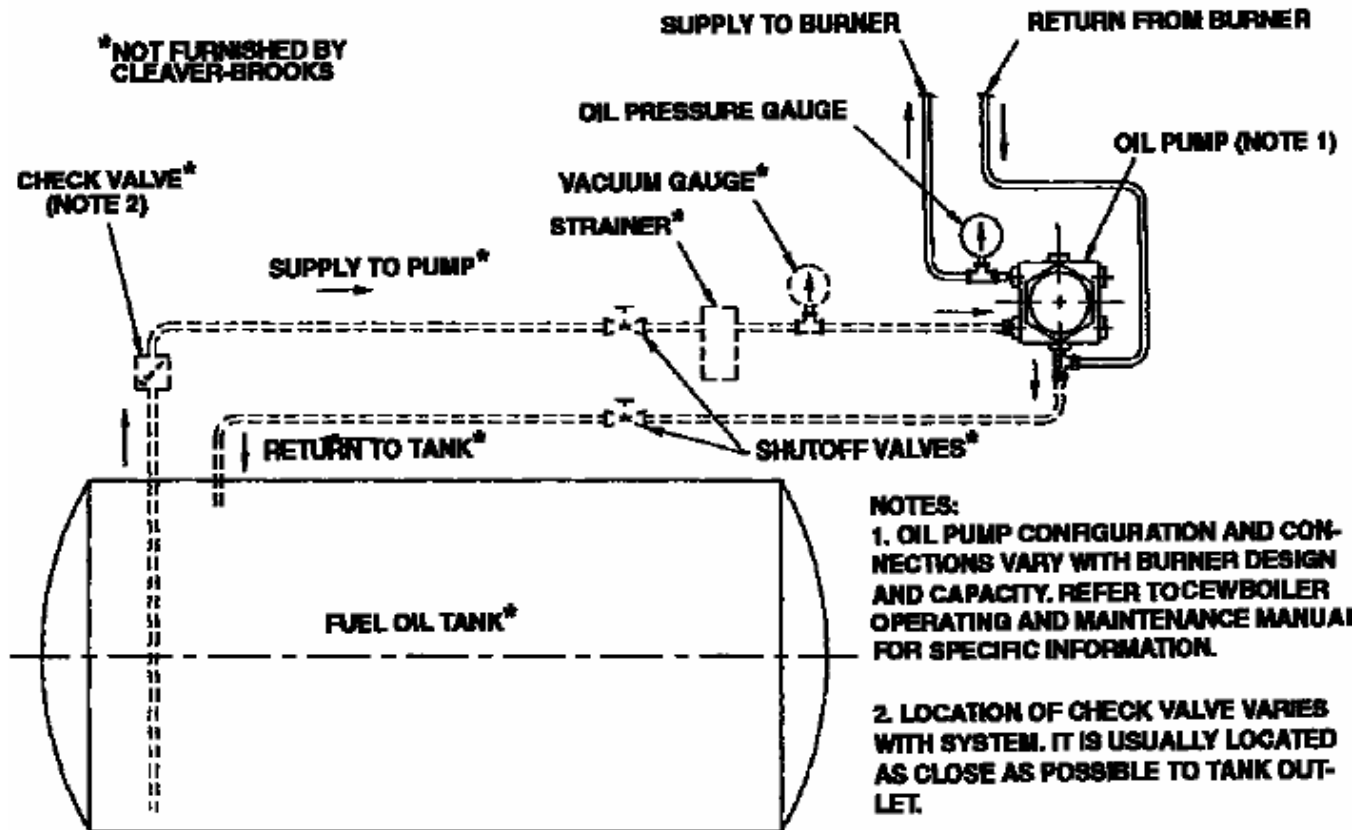
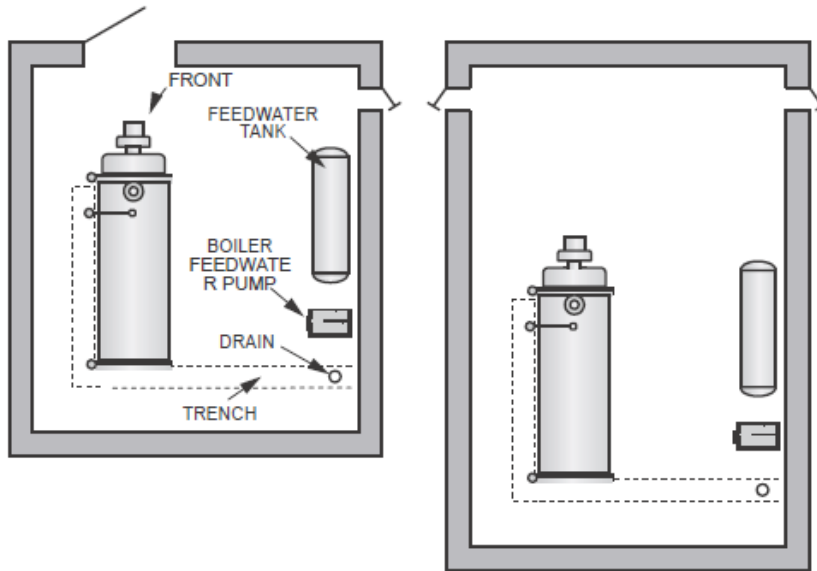
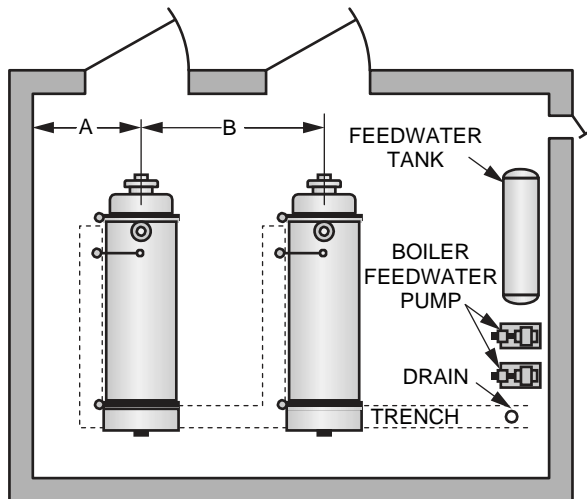

Figure A3-8. Typical Fuel Oil Supply Arrangement



1. Shortest boiler room length (Dwg A) is obtained by allowing for possible future tube replacement (from front or rear of boiler) through a window or doorway. Allowance is only made for minimum door swing at each end of the boiler. This arrangement provides sufficient aisle space at the front of the boiler but a "tight" space condition at the rear. If space permits, approximately 1.5 additional feet should be allowed at the rear for additional aisle and working space.
2. Next shortest boiler room length (Dwg B) is obtained by allowing for possible future tube replacement from the front of the boiler. Allowance is only made for minimum door swing at the rear. If space permits, approximately 1.5 additional feet should be allowed at the rear for additional aisle and working space.

**Figure A3-9. Boiler Room Length (Typical Layouts) - Model 4WG**



BOILER HP	100-125	150-200	250-300	350-400	500-600	700-800
DIM. "A"	87	91	96	100	105	110
DIM. "B"	120	127	144	151	174	184

**NOTES:**

Recommended Minimum Distance Between Boiler and Wall. Dimension "A" allows for a "clear" 42" aisle between the water column on the boiler and the wall. If space permits, this aisle should be widened.

Recommended Minimum Distance Between Boilers. Dimension "B" between boilers allows for a "clear" aisle of:  
 42" - 100-200 HP  
 48" - 250-400 HP  
 60" - 500-800 HP  
 If space permits, this aisle should be widened.

**Figure A3-10. Boiler Room Width (Typical Layouts) - Model 4WG**

## SAMPLE SPECIFICATIONS Model 4WG STEAM BOILERS

### PART 1 GENERAL

#### STEAM BOILERS

Cleaver Brooks Model 4WG

##### 1.01 SCOPE

- A. The work to be performed consists of providing all labor, equipment, materials, etc. to furnish and install new factory assembled steam boiler(s) as described in the specifications herein.
- B. Related Sections include the following:
  - 1. Division 15 Section "Chemical Water Treatment" for feedwater treatment and connections.
  - 2. Division 15 Section "Breechings, Chimneys, and Stacks" for connections to breechings, chimneys, and stacks.
  - 3. Division 15 Sections for control wiring for automatic temperature control.

##### 1.02 REFERENCES

- A. Product Data: Include rated capacities; shipping, installed, and operating weights; furnished specialties; and accessories for each model indicated.
- B. Shop Drawings: Detail equipment assemblies and indicate dimensions, required clearances, and method of field assembly, components, and location and size of each field connection.
- C. Wiring Diagrams: Detail wiring for power, signal, and control systems and differentiate between manufacturer-installed and field-installed wiring.
- D. Source Quality Control Tests and Inspection Reports: Indicate and interpret test results for compliance with performance requirements before shipping.
- E. Field Test Reports: Indicate and interpret test results for compliance with performance requirements.
- F. Maintenance Data: Include in the maintenance manuals specified in Division 1. Include parts list, maintenance guide, and wiring diagrams for each boiler.
  - 1. ASME Section (I or IV) (Power boilers or Heating Boilers)
  - 2. ANSI Z21.13 (Gas Fired Low Pressure Boilers)
  - 3. NFPA 54 (ANSI Z221.3) National Fuel Gas Code
  - 4. FACTORY MUTUAL
  - 5. ASME CSD-1 (Controls and Safety Devices)
  - 6. IRI (Industrial Risks Insurance)
  - 7. UBC (Uniform Building Code)
  - 8. UMC (Uniform Mechanical Code)
  - 9. NEC (National Electrical Code)
  - 10. UL (Underwriters Laboratories)
  - 11. NFPA 85

**1.03 QUALITY ASSURANCE**

- A. The equipment shall, as a minimum, be in strict compliance with the requirements of this specification and shall be the manufacturer's standard commercial product unless specified otherwise. Additional equipment features, details, accessories, appurtenances, etc. which are not specifically identified but which are a part of the manufacturer's standard commercial product, shall be included in the equipment being furnished.
- B. The equipment shall be of the type, design, and size that the manufacturer currently offered for sale and appears in the manufacturer's current catalogue. The equipment shall be new and fabricated from new materials and shall be free from defects in materials and workmanship
- C. The equipment must fit within the allocated space, leaving ample allowance for maintenance and cleaning, and must leave suitable space for easy removal of all equipment appurtenances. Tube pull clearance space from either the front or rear of boiler must be maintained.
- D. All units of the same classification shall be identical to the extent necessary to insure interchangeability of parts, assemblies, accessories, and spare parts wherever possible.
- E. In order to provide unit responsibility for the specified capacities, efficiencies, and performance, the boiler manufacturer shall certify in writing that the equipment being submitted shall perform as specified. The boiler manufacturer shall be responsible for guarantying that the boiler provides the performance as specified herein.

**1.04 SUBMITTALS**

- A. The contractor shall submit, in a timely manner, all submittals for approval by the engineer. Under no circumstances shall the contractor install any materials until the engineer has made final approval on the submittals.
- B. The engineer shall review and stamp submittals. Work may proceed and equipment released for fabrication after contractor receives returned submittals stamped with "NO EXCEPTIONS TAKEN" or "MAKE CORRECTIONS NOTED".
- C. The bidder must submit in writing to the engineer any request for a proposed deviation, omission, modification, or substitution to this specification for evaluation no later than ten (10) days prior to the bid date. A request for any substitution shall be accompanied by technical data, drawings, product samples, and complete data substantiating compliance of proposed substitution with these specifications. No materials shall be deemed acceptable if not in strict and full compliance with these specifications. All bidders must bid solely on the specified materials unless acceptance by the engineer of a deviation, omission, modification, or substitution is granted in writing to all bidders prior to the bid date.
- D. Shop Drawings - Shop drawings shall be submitted to the engineer for approval and shall consist of:
  - 1. General assembly drawing of the boiler including product description, model number, dimensions, clearances, weights, service sizes, etc.
  - 2. Schematic flow diagram of gas valve trains.
  - 3. Schematic wiring diagram of boiler control system of the ladder-type showing all components, all interlocks, etc. Schematic wiring diagram shall clearly identify factory wiring and field wiring.
- E. Installation Instructions: Manufacturer's printed instructions for installation shall be submitted to the engineer for approval.
- F. Manufacturer's Warranties: Manufacturer's printed warranties, as specified hereinafter, shall be submitted prior to final acceptance by the engineer.

- G. Manufacturer's Field Service: Manufacturer's printed field service procedures and reports, as specified hereinafter, shall be submitted prior to final acceptance by the engineer. Report forms shall contain all information as required to do start-up and testing as specified in the products section.

#### 1.05 CERTIFICATIONS

- A. Manufacturer's Certification: The boiler manufacturer shall certify the following:
1. The products and systems furnished are in strict compliance with the specifications.
  2. The boiler, burner and other associated mechanical and electrical equipment have all been properly coordinated and integrated to provide a complete and operable boiler.
  3. ASME certification.
  4. UL and CSD-1 certification.
  5. The equipment furnished has been installed in accordance with the manufacturer's installation instructions.
  6. The specified factory tests have been satisfactorily performed.
  7. The specified field tests have been satisfactorily performed.
- B. Contractor's Certification: The contractor shall certify the following:
1. The products and systems installed are in strict compliance with the specifications.
  2. The specified field tests have been satisfactorily performed.
- C. Boiler Inspectors' Certification: All boiler inspections during hydrostatic testing shall be performed by an authorized boiler inspector who is certified by the National Board of Boiler and Pressure Vessel Inspectors and shall be submitted in writing prior to final acceptance by the engineer.
- D. Test Reports: Factory and field test reports as described above and as specified hereinafter, shall be submitted prior to final acceptance by the engineer.
- E. Operation and Maintenance Manuals: Manufacturer's printed operation and maintenance manuals shall be submitted prior to final acceptance by the engineer. Operation and maintenance manuals shall contain shop drawings, product data, operating instructions, cleaning procedures, replacement parts list, maintenance and repair data, complete parts list, etc.

#### 1.06 DELIVERY, STORAGE, AND HANDLING

- A. The contractor shall be responsible for the timely delivery of the equipment to the job site. The contractor shall be responsible for unloading and rigging of the equipment. The contractor shall be responsible for protecting the equipment from the weather, humidity and temperature conditions, dirt, dust, other contaminants, as well as job site conditions during construction.
- B. Equipment shall be unloaded, handled, and stored in accordance with the manufacturer's handling and storage instructions.
- C. The work to be performed consists of providing all labor, equipment, materials, etc. to furnish and install new factory assembled, low pressure hot water boilers as described in the specifications herein.

**PART 2 PRODUCTS**

**2.01 MANUFACTURERS**

- A. Contractor shall furnish and install Cleaver Brooks Model 4WG natural gas (combination Gas/Oil fired) steam boiler(s) with design pressure as scheduled on the drawings.
- B. Alternate manufacturers complying with plans and specifications must be submitted and approved by the consulting engineer within 10 days prior to bid date.

**2.02 GENERAL DESCRIPTION**

Factory packaged unit shall include boiler, burner, heavy duty skids, painted steel jacket with two inches of fiberglass insulation, controls and accessories all piped and wired for single point field connections. Units shall carry packaged label of Underwriters Laboratory (UL) and be in accordance with ASME/CSD-1, all codes required by the local governing authorities and as indicated on the design performance data sheet. A certified factory fire-test shall be provided on all fuels with data sheets furnished to Engineer and Owner. ASME certified, labeled, stamped and designed for \_\_\_\_\_ PSIG steam in accordance with Section (I or IV) of ASME Code. Unit shall be designed to Seismic Zone \_\_\_\_\_ requirements and be provided with tie down clips and calculations showing bolt diameter requirements. Manufacturer's Representative to provide services for field testing and adjusting of boiler and controls to meet design requirements.

**2.03 PERFORMANCE: BOILER SIZE AND RATINGS**

- A. The capacity of each unit shall be indicated on the drawing schedule.
- B. Performance Criteria:

Performance Criteria	
Manufacturer:	CLEAVER-BROOKS
Model:	4WG
Horsepower:	_____ HP
Output:	_____ #/hr (from and at 212°F)
Gas Input:	_____ MB
Oil Input:	_____ GPH
Design Pressure:	_____ PSIG
Operating Pressure	_____ PSIG
Steam Disengaging Area (minimum)	_____ Sq. Inches
Steam storage area (minimum)	_____ Cu. Ft.
Heating Surface (minimum):	_____ Sq. Ft. Fireside
Heating Release (maximum):	_____ BTU/Cu. Ft.
Burner Turndown Ratio Natural Gas:	
No. 2 Oil:	
Overall Efficiency (Fuel to Steam)	
Natural Gas (%):	_____ % at High Fire
No. 2 Oil (%):	_____ % at High Fire
NOX Emission (maximum)	
Gas (Natural):	_____ PPM (corrected to 3%O <sub>2</sub> )
Oil (No. 2):	_____ PPM (corrected to 3%O <sub>2</sub> )
CO Emissions (maximum)	
Gas (Natural):	_____ PPM (corrected to 3%O <sub>2</sub> )
Oil (No. 2):	_____ PPM (corrected to 3%O <sub>2</sub> )



Performance Criteria	
Electrical:	_____ V / _____ H / _____ P
Fan Motor:	_____ HP
Air Compressor Motor:	_____ HP
Oil Pump Motor:	_____ HP
Noise Level (3' from burner):	_____ dBA
Available Gas Supply Pressure:	_____ PSIG
Weight	
Dry:	_____
Flooded:	_____
Seismic Zone:	_____
Altitude:	_____ ASL
Code Requirements:	ASME / NATIONAL BOARD CSD-1 NFPA 8501 Underwriter's Lab (UL) State Of _____ Factory Mutual (FM) Industrial Risk Insurers (IRI)

A. Noise Sound Levels: Based on ABMA test code for packaged boilers measured 4-1/2 feet vertically above the bottom of the base rail and 3'0" horizontally in front of the end of the blower motor or front surface of control cabinet. Sound levels dBA on the scale in reference to 0.0002 microbars.

High Fire	#2 oil	_____ dBA
Low Fire	#2 oil	_____ dBA
High Fire	Nat Gas	_____ dBA
Low Fire	Nat Gas	_____ dBA

**2.04 BOILER DESIGN**

- A. Four pass steel scotch marine firetube boiler for positive pressurized firing with forced draft burner. Wet-Back design with a minimum five (5) square feet of heating surface per boiler horsepower. Front and rear doors shall be davited and sealed with tad-pole gaskets using heavy duty cap screws threaded into replaceable brass nuts. When opened, doors shall expose all tubes, tubesheets and furnace for ease of inspection and maintenance. Lifting loops shall be provided. The rear door shall be insulated with a blanket material and a steel covering to give the surface a hard durable finish. The boiler tubes shall not include turbulators, swirlers or other add- on appurtenances. The boiler shall be furnished with a manhole and handholes to facilitate boiler inspection and cleaning.
- B. The boiler pressure vessel shall be completely insulated with a minimum of 2" of insulation and shall be encased in an 18 gauge metal cabinet with primer and finish coat of paint. The entire boiler based frame and other components shall be factory painted before shipment using a hard finish enamel coating.

## 2.05 BURNER DESIGN

- A. GENERAL: Forced draft burner of the gun design with hinged access for inspection and service. Reversed curve fabricated aluminum blower fan; motor(s); single point positioning system consisting of rotary air damper located on the combustion air intake, straight line linkage and characterized cams; air flow switch; fuel trains and control panels. To conform to UL and other insurance requirements as indicated.
- B. GAS BURNER: Shall be of the high radiant multi-port type for natural gas. Minimum pilot safety burner shall consist of gas-electric spark ignition with 100% safety shut-off pilot, solenoid gas valve, pressure regulator and shut-off cock. Minimum main gas train shall include manual shut-off valve, pressure regulating valve, dual safety gas valves, manual test valve high-low pressure switches, manifold pressure gauge and butterfly gas valve with (14) point characterized cam assembly. Gas train shall be factory packaged to meet insurance requirements as indicated. Gas turn down shall be minimum 5:1 for 250 to 800 HP.
- C. OIL BURNER Oil burner shall be of the low pressure air atomizing type for No. 2 oil. Minimum pilot safety burner shall consist of gas-electric spark ignition with 100% safety shut-off pilot, solenoid gas valve, pressure regulator and shut-off cock. Oil train shall consist of gauges, air purge valve; (14) point characterized cam assembly; dual oil solenoids; temperature switch, air compressor assembly and oil pump assembly. Oil train shall be factory packaged to meet insurance requirements as indicated. Oil turn down shall be minimum 5:1 for #2 Oil and 4:1 for Heavy Oil for 250 to 800 HP.
- D. COMBINATION BURNER: Provide gas-oil fuel selector switch to provide fuel switch over without any required adjustments to burner linkage.
- E. FUEL-AIR CONTROL: Modulating fire with proven low fire start. Provide manual potentiometer with manual-auto switch on boiler control panel in addition to automatic fuel-air controller. Linkage system shall be single point positioning with rotary air damper, linkage and (14) point characterized cam assembly for all fuels. Provide automatic operating control and manual reset high limit.
- F. FORCED DRAFT BLOWER: Backward curved aluminum radial impeller shall be directly connected to a flanged type ODP motor. The combustion air damper shall be an integral rotating damper and shall be automatically adjusted for proper air quantity by a mod motor to maintain proper fuel-air ratios.
- G. EMISSION CONTROL (optional): Boiler NOx shall be furnished with guaranteed external induced NOx control for 30 PPM corrected to 3% O<sub>2</sub> over the entire turndown range. Boiler capacity, turndown, flame stability and efficiency shall not be affected by the internal NOx control. Low NOx system shall be part of the Boiler/Burner UL package label and manufacture shall have Twelve (12) years of emission control experience in the state of \_\_\_\_\_.

## 2.06 BOILER TRIM

- A. To include the following:
  - 1. \_\_\_\_\_" diameter pressure gauge.
  - 2. ASME safety relief valve(s).
  - 3. Auxiliary Low Water Cutoff, (optional)
  - 4. Primary low water cut-off.
  - 5. Operating control.
  - 6. Limit control with manual reset.
  - 7. \_\_\_\_\_" stack thermometer.
  - 8. Feedwater regulating valve with 3 valve bypass
  - 9. Low fire hold controller (optional).
  - 10. 1 Slow Opening Blowdown Valve, Size \_\_\_\_\_", Class 200#

11. 2 Quick Opening Blowdown Valves, Size \_\_\_\_\_", Class 490#
  12. Feedwater Globe Valve, Size \_\_\_\_\_", Class 240# m.
  13. 1 Feedwater Check Valve, Size \_\_\_\_\_", Class 240# n.
  14. 1 ASME Spool Piece, Inlet Size \_\_\_\_\_", Outlet Size \_\_\_\_\_", Length \_\_\_\_\_"
  15. 1 Stop Valve (Steam Header Valve), Size \_\_\_\_\_", Flanged, Cast Iron, Class 250"
  16. 1 Stop Check Valve (Non-Return Valve), Size \_\_\_\_\_", Flanged, Cast Iron, Class 250", Straight Pattern, with Free Blow Drain Valve
  17. Factory mounted, installed, tested, and certified piping (by A, S, or PP ASME stamp holder) and valves per ASME Code, including:
    - Water Column piping
    - Bottom Blowdown (from boiler to last code valve)
    - Feedwater assembly (shipped loose)
    - Surface Blowdown piping with stop valve and metering valve.
  18. JHB Modulating Feedwater Control Valve, including 3-Valve Bypass
  19. Oil Pump, Mounted and Wired
  20. Air Atomizing Compressor, Mounted and Wired
  21. Platforms and ladder to access steam header and safety relief valves. Built to OSHA requirements.
- B. WATER COLUMN/LOW WATER CUTOFF AND WATER LEVEL CONTROL SYSTEM: McDonnell & Miller 157.

## 2.07 BOILER CONTROLS

- A. BOILER MANAGEMENT CONTROL SYSTEM CONTROL PANEL: Boiler mounted NEMA 1 enclosure(s) with key lock; fusing, magnetic starters; step-down control transformer; flame safeguard and burner management system as indicated; annunciator lights for load demand, fuel on, low water and flame failure; selector switches, required by dry contacts, relays and terminal strips. Oil, heat and moisture resistant wire with circuit number corresponding to electrical wiring diagrams. In accordance with UL and National Electric Code.
- B. (OPTION 1) BURNER MANAGEMENT SYSTEM (CB 120; standard): Boiler mounted in control panel enclosure. Microprocessor-based control to monitor all critical boiler and burner interlocks control and supervise burner light off sequence, and initiate an orderly safety procedure in the event of interlock or flame failure. Dynamic self checking. System to provide pre-post purge status, fault history, and diagnostic information by means of a two-line alpha-numeric display (optional) with alarm/status LEDs.
- C. (OPTION 2) CB-HAWK ICS Boiler Control System - Integrated Boiler Control and Management System combining a Digital Burner Management System for flame safety, and a Programmable Logic Controller for boiler modulation and operator interface functions. The factory pre-configured Boiler Control System shall integrate the Burner Management functions and the PLC based modulation and operator interface functions. The logic of the Burner Management System and the modulating controls will not be run in the same processor or be powered by the same DC supply. The PLC and Operator Interface Hardware shall be as manufactured by Allen Bradley. Major system components shall include:
  1. Programmable Logic Controller
  2. Touch Screen HMI

3. One Burner Management Controller with Wiring Sub-Base
  4. One Flame Scanner and amplifier
  5. Various Temperature and Pressure Sensors
- D. Major functions provided by the Boiler Control System shall be:
1. Automatic sequencing of the boiler through standby, pre-purge, pilot flame establishing period, main flame establishing period, run, flame proving and lockout and post-purge
  2. Full modulating control of fuel and air
  3. Utilize solid state controls and sensors to provide various control functions, such as:
    - a. Modulating control (algorithm shall be Proportional-Integral-Derivative (PID) type)
    - b. Thermal shock protection
    - c. High and Low limit alarms and shutdowns
  4. Touch Screen graphical operator interface and monitoring
    - a. Manual control of the boiler firing rate using control screens on the HMI to increment or decrement the firing rate
    - b. On screen indication of burner management controller status and diagnostics
    - c. On screen display of system alarms and faults
    - d. On screen history of alarms and faults
    - e. On screen recommendations for troubleshooting of fault conditions
    - f. On screen water level indication and alarm(s)
  5. Stack Flue Gas, Combustion Air and Shell (water) temperature indication
  6. Boiler efficiency calculation
  7. Low Fire Hold with Minimum Temperature Control
  8. Assured Low Fire Cut-Off (ALFCO)
- E. The Boiler Control System shall incorporate the following safety provisions:
1. Examine all load terminals to assure it is capable of recognizing the true status of the external controls, limits and interlocks. If any input fails this test, the Burner Management System shall lockout on safety shutdown.
  2. Closed-loop logic test of critical loads (ignition, pilot and main fuel valves) and must be able to lockout on safety.
  3. Pre-ignition interlocks (fuel valve proof of closure, etc.) and flame signal checked during Standby and Pre-Purge.
  4. Dynamic checking of the flame signal amplifier.
  5. Safe start check and expand check to include monitoring flame signal during standby.
  6. High and Low fire switches checked for proper sequencing.
  7. The Boiler Control System shall provide the ability to communicate with external digital via Ethernet as a standard. It shall be possible to communicate with any OPC compliant Internet communications shall be supported, with the Boiler Control System supplied with its own IP address.

**2.08 SHOP TEST**

- A. Shop test: The complete packaged boiler shall receive factory tests to check construction and function of all controls. All shop tests may be witnessed by the purchaser at his own c upon sufficient notice to the company.

**2.9 ACCESSORIES - BOILER FLUE VENT****2.10 ACCESSORIES - FEEDWATER SYSTEM (BOILER FEEDSET OR DEAERATOR)****2.11 ACCESSORIES - FEEDWATER HEATER OR ECONOMIZER****2.12 ACCESSORIES - BLOWDOWN SEPARATOR AND/OR BLOWDOWN HEAT RECOVERY****2.13 ACCESSORIES - O<sub>2</sub> TRIM SYSTEM AND/OR****2.14 ACCESSORIES - CHEMICAL FEED SYSTEM AND/OR WATER TREATMENT****2.15 MANUFACTURES FIELD SERVICES**

- A. General: The boiler and accessories supplier shall be responsible for performance of insp up and testing of the package boiler and accessory equipment and materials furnished under Section. A detailed written record of the start up performance, including burner setting data entire load range shall be furnished to the test engineer before test personnel leave the site equipment and test apparatus shall be furnished by the supplier. All equipment defects discovered by the tests shall be rectified. The minimum time for two (2) boilers is five (5) days.
- B. Equipment inspection: Boiler representative to provide \_\_\_\_\_ hours of job site assistance to i boilers and other equipment upon arrival, verifying completeness of equipment supplied ar damages. Responsibility of making freight claims to be performed by contractor or owner personnel.
- C. Pre start-up walk through: Boiler representative shall spend \_\_\_\_\_ hours at job site reviewing with mechanical contractor to be conducted approximately 1 week prior to startup.
- D. Start-up shall be conducted by experienced and factory authorized technician in the regular employment of the boiler supplier, and shall include:
1. Demonstrate that boiler, burner, controls and accessories comply with requirement Section as proposed by the boiler and accessories supplier. Pre-test all items prior to scheduling the final testing that will be witnessed by the test engineer.
  2. Readings at different firing rates (25, 50, 75 and 100%) of load for the modulating burner shall be taken with a written report of the tests submitted to the test engineer. The reports shall include readings for each firing rate tested and include stack temperatures, O<sub>2</sub>, CO, NO<sub>x</sub> and overall boiler efficiency.
  3. Auxiliary Equipment and Accessories: Observe and check all valves, draft fans, electric motors and other accessories and appurtenant equipment during the operational and capacity tests for leakage, malfunctioning, defects, and non compliance with referenced standards or overloading as applicable.
  4. Commissioning Requirements:
    - a. Fireside inspection
    - b. Waterside inspection
    - c. Closing and resealing of doors, manways and hand holes
    - d. Set up fuel train and combustion air system

- e. Set up operating set points
  - f. Check all safeties, including: Flame safeguard, LWCO, ALWCO, Air flow, Fuel pressures, High limits
  - g. Set up and verify efficiencies at 25%, 50%, 75%, and 100%
  - h. Set up and verify burner turndown.
  - i. Set up and verify feedwater/level controls
  - j. Set up and verify Emissions Compliance
5. Training to include all safety procedures, maintenance procedures, control operations, and diagnostic procedures. Training to be provided in a single-hour continuous session to accommodate operator's availability on site.
6. Special tool / safety equipment:
- a. Boiler/burner supplier to include in their proposal safety equipment required to perform annual inspections and maintenance per OSHA requirements, Section 29CFR, 1910.146, date 4115193, Paragraphs 5.6.4.2 through 5.6.6.6 confined space requirements on rear furnace and flue gas turnaround area. Items to include respirator, tag out devices, atmospheric tester, acid suit, harness, wrist straps, life wire, and safety belt
  - b. Special Safety Training on safety procedures by a qualified trainer to be provided per OSHA Section 1910.146, Paragraph 5.6.5.2, to all owners and employees who are operating specified equipment. The cost of training to be included in boiler supplier's proposal

## 2.16 OPERATING & MAINTENANCE MANUALS

- A. Provide two (2) Operating and Maintenance manuals including cut-away views of boiler and burner, schematics including fuel trains, general instructions for maintenance and inspections, complete spare parts lists and trouble shooting procedures. Operating and maintenance manuals shall be provided including cut-away views of boiler and burner schematics including fuel trains, general instructions for maintenance and inspections, complete spare parts lists and trouble shooting procedures.
- B. A wiring diagram corresponding to the boiler shall be affixed to the boiler near the electrical panel.

## 2.17 WARRANTY DATA

- A. The entire boiler/burner package shall be guaranteed and warranted by the boiler manufacturer. Warranty shall include all parts for a period of (12) months from the date of start-up or beneficial use or 18 months from shipment, whichever comes first.

# PART 3 EXECUTION

## 3.01 GENERAL

- A. Installation shall be provided by the contractor in accordance with the requirements of the codes specified hereinbefore. All of the contractor's work shall be performed by experienced workman previously engaged in boiler plant construction and shall be under the supervision of a qualified installation supervisor.

**3.02 INSTALLATION**

- A. Install equipment in strict compliance with manufacturer's installation instructions.
- B. Install equipment in strict compliance with state and local codes and applicable NFPA standards.
- C. Maintain manufacturer's recommended clearances around sides and over top of equipment.
- D. Install components that were removed from equipment for shipping purposes.
- E. Install components that were furnished loose with equipment for field installation.
- F. Provide all interconnecting electrical control and power wiring.
- G. Provide all fuel gas vent and service piping.
- H. Provide all piping for boiler pipe connections.

**3.03 FIELD TESTING**

- A. The manufacturer's representative shall test all boiler and burner interlocks, actuators, valves, controllers, gauges, thermometers, pilot lights, switches, etc. Any malfunctioning component shall be replaced.
- B. All adjustments to boiler, burner, and boiler control system shall be performed by the manufacturer's representative.

**3.04 START-UP, INSTRUCTION AND WARRANTY SERVICE**

The manufacturer's representative shall provide start-up and instruction of each new boiler, including burner and boiler control system as specified herein. Start-up and instruction shall cover all components assembled and furnished by the manufacturer whether or not of his own manufacture.

## Notes

## SAMPLE SPECIFICATIONS MODEL 4WG HOT WATER BOILERS

### PART 1 GENERAL

#### HOT WATER

Cleaver Brooks Model 4WG

#### 1.01 SCOPE

- A. The work to be performed consists of providing all labor, equipment, materials, etc. to furnish and install new factory assembled steam boiler(s) as described in the specifications herein.
- B. Related Sections include the following:
  - 1. Division 15 Section "Chemical Water Treatment" for feedwater treatment and connections.
  - 2. Division 15 Section "Breechings, Chimneys, and Stacks" for connections to breechings, chimneys, and stacks.
  - 3. Division 15 Sections for control wiring for automatic temperature control.

#### 1.02 REFERENCES

- A. Product Data: Include rated capacities; shipping, installed, and operating weights; furnished specialties; and accessories for each model indicated.
- B. Shop Drawings: Detail equipment assemblies and indicate dimensions, required clearances, and method of field assembly, components, and location and size of each field connection.
- C. Wiring Diagrams: Detail wiring for power, signal, and control systems and differentiate between manufacturer-installed and field-installed wiring.
- D. Source Quality Control Tests and Inspection Reports: Indicate and interpret test results for compliance with performance requirements before shipping.
- E. Field Test Reports: Indicate and interpret test results for compliance with performance requirements.
- F. Maintenance Data: Include in the maintenance manuals specified in Division 1. Include parts list, maintenance guide, and wiring diagrams for each boiler.
  - 1. ASME Section (I or IV) (Power boilers or Heating Boilers)
  - 2. ANSI Z21.13 (Gas Fired Low Pressure Boilers)
  - 3. NFPA 54 (ANSI Z221.3) National Fuel Gas Code
  - 4. FACTORY MUTUAL
  - 5. ASME CSD-1 (Controls and Safety Devices)
  - 6. IRI (Industrial Risks Insurance)
  - 7. UBC (Uniform Building Code)
  - 8. UMC (Uniform Mechanical Code)
  - 9. NEC (National Electrical Code)
  - 10. UL (Underwriters Laboratories)
  - 11. NFPA 85

**1.03 QUALITY ASSURANCE**

- A. The equipment shall, as a minimum, be in strict compliance with the requirements of this specification and shall be the manufacturer's standard commercial product unless specified otherwise. Additional equipment features, details, accessories, appurtenances, etc. which are not specifically identified but which are a part of the manufacturer's standard commercial product, shall be included in the equipment being furnished.
- B. The equipment shall be of the type, design, and size that the manufacturer currently offered for sale and appears in the manufacturer's current catalogue. The equipment shall be new and fabricated from new materials and shall be free from defects in materials and workmanship
- C. The equipment must fit within the allocated space, leaving ample allowance for maintenance and cleaning, and must leave suitable space for easy removal of all equipment appurtenances. Tube pull clearance space from either the front or rear of boiler must be maintained.
- D. All units of the same classification shall be identical to the extent necessary to insure interchangeability of parts, assemblies, accessories, and spare parts wherever possible.
- E. In order to provide unit responsibility for the specified capacities, efficiencies, and performance, the boiler manufacturer shall certify in writing that the equipment being submitted shall perform as specified. The boiler manufacturer shall be responsible for guarantying that the boiler provides the performance as specified herein.

**1.04 SUBMITTALS**

- A. The contractor shall submit, in a timely manner, all submittals for approval by the engineer. Under no circumstances shall the contractor install any materials until the engineer has made final approval on the submittals.
- B. The engineer shall review and stamp submittals. Work may proceed and equipment released for fabrication after contractor receives returned submittals stamped with "NO EXCEPTIONS TAKEN" or "MAKE CORRECTIONS NOTED".
- C. The bidder must submit in writing to the engineer any request for a proposed deviation, omission, modification, or substitution to this specification for evaluation no later than ten (10) days prior to the bid date. A request for any substitution shall be accompanied by technical data, drawings, product samples, and complete data substantiating compliance of proposed substitution with these specifications. No materials shall be deemed acceptable if not in strict and full compliance with these specifications. All bidders must bid solely on the specified materials unless acceptance by the engineer of a deviation, omission, modification, or substitution is granted in writing to all bidders prior to the bid date.
- D. Shop Drawings - Shop drawings shall be submitted to the engineer for approval and shall consist of:
  - 1. General assembly drawing of the boiler including product description, model number, dimensions, clearances, weights, service sizes, etc.
  - 2. Schematic flow diagram of gas valve trains.
  - 3. Schematic wiring diagram of boiler control system of the ladder-type showing all components, all interlocks, etc. Schematic wiring diagram shall clearly identify factory wiring and field wiring.
- E. Installation Instructions: Manufacturer's printed instructions for installation shall be submitted to the engineer for approval.
- F. Manufacturer's Warranties: Manufacturer's printed warranties, as specified hereinafter, shall be submitted prior to final acceptance by the engineer.

- G. Manufacturer's Field Service: Manufacturer's printed field service procedures and reports, as specified hereinafter, shall be submitted prior to final acceptance by the engineer. Report forms shall contain all information as required to do start-up and testing as specified in the products section.

#### 1.05 CERTIFICATIONS

- A. Manufacturer's Certification: The boiler manufacturer shall certify the following:
1. The products and systems furnished are in strict compliance with the specifications.
  2. The boiler, burner and other associated mechanical and electrical equipment have all been properly coordinated and integrated to provide a complete and operable boiler.
  3. ASME certification.
  4. UL and CSD-1 certification.
  5. The equipment furnished has been installed in accordance with the manufacturer's installation instructions.
  6. The specified factory tests have been satisfactorily performed.
  7. The specified field tests have been satisfactorily performed.
- B. Contractor's Certification: The contractor shall certify the following:
1. The products and systems installed are in strict compliance with the specifications.
  2. The specified field tests have been satisfactorily performed.
- C. Boiler Inspectors' Certification: All boiler inspections during hydrostatic testing shall be performed by an authorized boiler inspector who is certified by the National Board of Boiler and Pressure Vessel Inspectors and shall be submitted in writing prior to final acceptance by the engineer.
- D. Test Reports: Factory and field test reports as described above and as specified hereinafter, shall be submitted prior to final acceptance by the engineer.
- E. Operation and Maintenance Manuals: Manufacturer's printed operation and maintenance manuals shall be submitted prior to final acceptance by the engineer. Operation and maintenance manuals shall contain shop drawings, product data, operating instructions, cleaning procedures, replacement parts list, maintenance and repair data, complete parts list, etc.

#### 1.06 DELIVERY, STORAGE, AND HANDLING

- A. The contractor shall be responsible for the timely delivery of the equipment to the job site. The contractor shall be responsible for unloading and rigging of the equipment. The contractor shall be responsible for protecting the equipment from the weather, humidity and temperature conditions, dirt, dust, other contaminants, as well as job site conditions during construction.
- B. Equipment shall be unloaded, handled, and stored in accordance with the manufacturer's handling and storage instructions.
- C. The work to be performed consists of providing all labor, equipment, materials, etc. to furnish and install new factory assembled, low pressure hot water boilers as described in the specifications herein.

**PART 2 PRODUCTS**

**2.01 MANUFACTURERS**

- A. Contractor shall furnish and install Cleaver Brooks Model 4WG natural gas (combination Gas/Oil fired) steam boiler(s) with design pressure as scheduled on the drawings.
- B. Alternate manufacturers complying with plans and specifications must be submitted and approved by the consulting engineer within 10 days prior to bid date.

**2.02 GENERAL DESCRIPTION**

Factory packaged unit shall include boiler, burner, heavy duty skids, painted steel jacket with two inches of fiberglass insulation, controls and accessories all piped and wired for single point field connections. Units shall carry packaged label of Underwriters Laboratory (UL) and be in accordance with ASME/CSD-1, all codes required by the local governing authorities and as indicated on the design performance data sheet. A certified factory fire-test shall be provided on all fuels with data sheets furnished to Engineer and Owner. ASME certified, labeled, stamped and designed for \_\_\_\_\_ PSIG steam in accordance with Section (I or IV) of ASME Code. Unit shall be designed to Seismic Zone \_\_\_\_\_ requirements and be provided with tie down clips and calculations showing bolt diameter requirements. Manufacturer's Representative to provide services for field testing and adjusting of boiler and controls to meet design requirements.

**2.03 PERFORMANCE: BOILER SIZE AND RATINGS**

- A. The capacity of each unit shall be indicated on the drawing schedule.
- B. Performance Criteria:

Performance Criteria	
Manufacturer:	CLEAVER-BROOKS
Model:	4WG
Horsepower:	_____ HP
Output:	_____ #/hr (from and at 212°F)
Gas Input:	_____ MB
Oil Input:	_____ GPH
Design Pressure:	_____ PSIG
Operating Pressure	_____ PSIG
Steam Disengaging Area (minimum)	_____ Sq. Inches
Steam storage area (minimum)	_____ Cu. Ft.
Heating Surface (minimum):	_____ Sq. Ft. Fireside
Heating Release (maximum):	_____ BTU/Cu. Ft.
Burner Turndown Ratio Natural Gas:	
No. 2 Oil:	
Overall Efficiency (Fuel to Steam)	
Natural Gas (%):	_____ % at High Fire
No. 2 Oil (%):	_____ % at High Fire
NOX Emission (maximum)	
Gas (Natural):	_____ PPM (corrected to 3%O <sub>2</sub> )
Oil (No. 2):	_____ PPM (corrected to 3%O <sub>2</sub> )
CO Emissions (maximum)	
Gas (Natural):	_____ PPM (corrected to 3%O <sub>2</sub> )
Oil (No. 2):	_____ PPM (corrected to 3%O <sub>2</sub> )



Performance Criteria	
Electrical:	_____ V / _____ H / _____ P
Fan Motor: Air Compressor Motor:	_____ HP
Oil Pump Motor:	_____ HP
Noise Level (3' from burner):	_____ dBA
Available Gas Supply Pressure:	_____ PSIG
Weight	
Dry:	_____
Flooded:	_____
Seismic Zone:	_____
Altitude:	_____ ASL
Code Requirements:	ASME / NATIONAL BOARD CSD-1 NFPA 8501  Underwriter's Lab (UL) State Of _____ Factory Mutual (FM)  Industrial Risk Insurers (IRI)

A. Noise Sound Levels: Based on ABMA test code for packaged boilers measured 4-1/2 feet vertically above the bottom of the base rail and 3'0" horizontally in front of the end of the blower motor or front surface of control cabinet. Sound levels dBA on the scale in reference to 0.0002 microbars.

High Fire	#2 oil	_____ dBA
Low Fire	#2 oil	_____ dBA
High Fire	Nat Gas	_____ dBA
Low Fire	Nat Gas	_____ dBA

## 2.04 BOILER DESIGN

- A. Four pass steel scotch marine firetube boiler for positive pressurized firing with forced draft burner. Wet back design with a minimum five (5) square feet of heating surface per boiler horsepower. Front and rear doors shall be davited and sealed with tad-pole gaskets using heavy duty cap screws threaded into replaceable brass nuts. When opened, doors shall expose all tubes, tubesheets and furnace for ease of inspection and maintenance. Lifting loops shall be provided. The rear door shall be insulated with a blanket material and a steel covering to give the surface a hard durable finish. The boiler tubes shall not include turbulators, swirlers or other add-on appurtenances. The boiler shall be furnished with a manhole and handholes to facilitate boiler inspection and cleaning.
- B. The boiler pressure vessel shall be completely insulated with a minimum of 2" of insulation and shall be encased in an 18 gauge metal cabinet with primer and finish coat of paint. The entire boiler based frame and other components shall be factory painted before shipment using a hard finish enamel coating.

**2.05 BURNER DESIGN**

- A. GENERAL: Forced draft burner of the gun design with hinged access for inspection and service. Reversed curve fabricated aluminum blower fan; motor(s); single point positioning system consisting of rotary air damper located on the combustion air intake, straight line linkage and characterized cams; air flow switch; fuel trains and control panels. To conform to UL and other insurance requirements as indicated.
- B. GAS BURNER: Shall be of the high radiant multi-port type for natural gas. Minimum pilot safety burner shall consist of gas-electric spark ignition with 100% safety shut-off pilot, solenoid gas valve, pressure regulator and shut-off cock. Minimum main gas train shall include manual shut-off valve, pressure regulating valve, dual safety gas valves, manual test valve high-low pressure switches, manifold pressure gauge and butterfly gas valve with (14) point characterized cam assembly. Gas train shall be factory packaged to meet insurance requirements as indicated. Gas turn down shall be minimum 5:1 for 250 to 800 HP.
- C. OIL BURNER Oil burner shall be of the low pressure air atomizing type for No. 2 oil. Minimum pilot safety burner shall consist of gas-electric spark ignition with 100% safety shut-off pilot, solenoid gas valve, pressure regulator and shut-off cock. Oil train shall consist of gauges, air purge valve; (14) point characterized cam assembly; dual oil solenoids; temperature switch, air compressor assembly and oil pump assembly. Oil train shall be factory packaged to meet insurance requirements as indicated. Oil turn down shall be minimum 5:1 for #2 Oil and 4:1 for Heavy Oil for 250 to 800 HP.
- D. COMBINATION BURNER: Provide gas-oil fuel selector switch to provide fuel switch over without any required adjustments to burner linkage.
- E. FUEL-AIR CONTROL: Modulating fire with proven low fire start. Provide manual potentiometer with manual-auto switch on boiler control panel in addition to automatic fuel-air controller. Linkage system shall be Cleaver-Brooks single point positioning with rotary air damper, linkage and (14) point characterized cam assembly for all fuels. Provide automatic operating control and manual reset high limit.
- F. FORCED DRAFT BLOWER: The Backward curved aluminum radial impeller shall be directly connected to a flanged type ODP motor. This rigid mounting shall eliminate vibration and reduce noise level. The balanced blower wheel shall be aluminum with radial blades. The combustion air damper shall be an integral rotating damper and shall be automatically adjusted for proper air quantity by a mod motor to maintain proper fuel-air ratios.
- G. EMISSION CONTROL (optional): Boiler NO<sub>x</sub> shall be furnished with guaranteed external induced NO<sub>x</sub> control for 30 PPM corrected to 3% O<sub>2</sub> over the entire turndown range. Boiler capacity, turndown, flame stability and efficiency shall not be affected by the internal NO<sub>x</sub> control. Low NO<sub>x</sub> system shall be part of the Boiler/Burner UL package label and manufacture shall have Twelve (12) years of emission control experience in the state of \_\_\_\_\_.

**2.06 BOILER TRIM**

- A. To include the following:
  - 1. \_\_\_\_\_" diameter temperature gauge.
  - 2. \_\_\_\_\_" diameter pressure gauge.
  - 3. ASME safety relief valve(s).
  - 4. Low water cutoff McD-M No. PS-750 MT-120
  - 5. Operating control.
  - 6. Limit control with manual reset.

7. \_\_\_\_\_ " stack thermometer.
8. Feedwater regulating valve with 3 valve bypass
9. Low fire hold controller (optional).
10. 1 Slow Opening Blowdown Valve, Size \_\_\_\_\_", Class 200#
11. 2 Quick Opening Blowdown Valves, Size \_\_\_\_\_", Class 490#
12. Feedwater Globe Valve, Size \_\_\_\_\_", Class 240# m.
13. 1 Feedwater Check Valve, Size \_\_\_\_\_", Class 240# n.
14. 1 ASME Spool Piece, Inlet Size \_\_\_\_\_", Outlet Size \_\_\_\_\_", Length \_\_\_\_\_"
15. 1 Stop Valve (Steam Header Valve), Size \_\_\_\_\_", Flanged, Cast Iron, Class 250"
16. 1 Stop Check Valve (Non-Return Valve), Size \_\_\_\_\_", Flanged, Cast Iron, Class 250", Straight Pattern, with Free Blow Drain Valve
17. Factory mounted, installed, tested, and certified piping (by A, S, or PP ASME stamp holder) and valves per ASME Code, including:
  - Water Column piping
  - Bottom Blowdown (from boiler to last code valve)
  - Feedwater assembly (shipped loose)
  - Surface Blowdown piping with stop valve and metering valve.
18. JHB Modulating Feedwater Control Valve, including 3-Valve Bypass
19. Oil Pump, Mounted and Wired
20. Air Atomizing Compressor, Mounted and Wired
21. Platforms and ladder to access safety relief valves. Built to OSHA requirements.

## 2.07 BOILER CONTROLS

- A. BOILER MANAGEMENT CONTROL SYSTEM CONTROL PANEL: Boiler mounted NEMA 1 enclosure(s) with key lock; fusing, magnetic starters; step-down control transformer; flame safeguard and burner management system as indicated; annunciator lights for load demand, fuel on, low water and flame failure; selector switches, required by dry contacts, relays and terminal strips. Oil, heat and moisture resistant wire with circuit number corresponding to electrical wiring diagrams. In accordance with UL and National Electric Code.
- B. (OPTION 1) BURNER MANAGEMENT SYSTEM (CB 780-Standard): Boiler mounted in control panel enclosure. Microprocessor-based control to monitor all critical boiler and burner interlocks control and supervise burner light off sequence, and initiate an orderly safety procedure in the event of interlock or flame failure. Dynamic self checking. System to provide pre-post purge status, fault history, and diagnostic information by means of a two-line alpha-numeric display with alarm/status LEDs.
- C. (OPTION 2) CB-HAWK ICS Boiler Control System (Optional upgrade): Burner Management System (CB HAWK ICS - optional upgrade): Integrated Boiler Control and Management System: Boiler shall be factory equipped with a Boiler Control System combining a Digital Burner Management System for flame safety, and a Programmable Logic Controller for boiler modulation and operator interface functions. The factory pre-configured Boiler Control System shall integrate the Burner Management functions and the PLC based modulation and operator interface functions. The logic of the Burner Management System and the modulating controls will not be run in the same processor or powered by the same DC supply. The PLC and Operator Interface Hardware shall be as manufactured by Allen Bradley.

Major system components shall include:

1. Programmable Logic Controller
2. Touch Screen HMI
3. One Burner Management Controller with Wiring Sub-Base
4. One Flame Scanner and amplifier
5. Various Temperature and Pressure Sensors

D. Major functions provided by the Boiler Control System shall be:

1. Automatic sequencing of the boiler through standby, pre-purge, pilot flame establishing period, main flame establishing period, run, flame proving and lockout and post-purge
2. Full modulating control of fuel and air
3. Utilize solid state controls and sensors to provide various control functions, such as:
  - a. Modulating control (algorithm shall be Proportional-Integral-Derivative (PID) type)
  - b. Thermal shock protection
  - c. High and Low limit alarms and shutdowns
4. Touch Screen graphical operator interface and monitoring
  - a. Manual control of the boiler firing rate using control screens on the HMI to increment or decrement the firing rate
  - b. On screen indication of burner management controller status and diagnostics
  - c. On screen display of system alarms and faults
  - d. On screen history of alarms and faults
  - e. On screen recommendations for troubleshooting of fault conditions
  - f. On screen water level indication and alarm(s)
5. Stack Flue Gas, Combustion Air and Shell (water) temperature indication
6. Boiler efficiency calculation
7. Low Fire Hold with Minimum Temperature Control
8. Assured Low Fire Cut-Off (ALFCO)

E. The Boiler Control System shall incorporate the following safety provisions:

1. Examine all load terminals to assure it is capable of recognizing the true status of the external controls, limits and interlocks. If any input fails this test, the Burner Management System shall lockout on safety shutdown.
2. Closed-loop logic test of critical loads (ignition, pilot and main fuel valves) and must be able to lockout on safety.
3. Pre-ignition interlocks (fuel valve proof of closure, etc.) and flame signal checked during Standby and Pre-Purge.
4. Dynamic checking of the flame signal amplifier.
5. Safe start check and expand check to include monitoring flame signal during standby.

6. High and Low fire switches checked for proper sequencing.
7. The Boiler Control System shall provide the ability to communicate with external digital via Ethernet as a standard. It shall be possible to communicate with any OPC compliant Internet communications shall be supported, with the Boiler Control System supplied with its own IP address.

## 2.08 SHOP TEST

- A. Shop test: The complete packaged boiler shall receive factory tests to check construction and function of all controls. All shop tests may be witnessed by the purchaser at his own c upon sufficient notice to the company.

## 2.9 ACCESSORIES - BOILER FLUE VENT

## 2.10 ACCESSORIES - FEEDWATER SYSTEM (BOILER FEEDSET OR DEAERATOR)

## 2.11 ACCESSORIES - FEEDWATER HEATER OR ECONOMIZER

## 2.12 ACCESSORIES - BLOWDOWN SEPARATOR AND/OR BLOWDOWN HEAT RECOVERY

## 2.13 ACCESSORIES - O<sub>2</sub> TRIM SYSTEM AND/OR

## 2.14 ACCESSORIES - CHEMICAL FEED SYSTEM AND/OR WATER TREATMENT

## 2.15 MANUFACTURES FIELD SERVICES

- A. General: The boiler and accessories supplier shall be responsible for performance of insp up and testing of the package boiler and accessory equipment and materials furnished un~ Section. A detailed written record of the start up performance, including burner setting dat entire load range shall be furnished to the test engineer before test personnel leave the sit equipment and test apparatus shall be furnished by the supplier. All equipment defects discovered by the tests shall be rectified. The minimum time for two (2) boilers is five (5) days.
- B. Equipment inspection: Boiler representative to provide \_\_\_\_\_ hours of job site assistance to i boilers and other equipment upon arrival, verifying completeness of equipment supplied ar damages. Responsibility of making freight claims to be performed by contractor or owner personnel.
- C. Pre start-up walk through: Boiler representative shall spend \_\_\_\_\_ hours at job site reviewing with mechanical contractor to be conducted approximately 1 week prior to startup.
- D. Start-up shall be conducted by experienced and factory authorized technician in the regular employment of the boiler supplier, and shall include:
  1. Demonstrate that boiler, burner, controls and accessories comply with requirement Section as proposed by the boiler and accessories supplier. Pre-test all items prior to scheduling the final testing that will be witnessed by the test engineer.
  2. Readings at different firing rates (25, 50, 75 and 100%) of load for the modulating burner shall be taken with a written report of the tests submitted to the test engineer. The reports shall include readings for each firing rate tested and include stack temperatures, O<sub>2</sub>, CO, NO<sub>x</sub> and overall boiler efficiency.
  3. Auxiliary Equipment and Accessories: Observe and check all valves, draft fans, electric motors and other accessories and appurtenant equipment during the operational and capacity tests for leakage, malfunctioning, defects, and non compliance with referenced standards or overloading as applicable.

4. Commissioning Requirements:
  - a. Fireside inspection
  - b. Waterside inspection
  - c. Closing and resealing of doors, manways and hand holes
  - d. Set up fuel train and combustion air system
  - e. Set up operating set points
  - f. Check all safeties, including: Flame safeguard, LWCO, ALWCO, Air flow, Fuel pressures, High limits
  - g. Set up and verify efficiencies at 25%, 50%, 75%, and 100%
  - h. Set up and verify burner turndown.
  - i. Set up and verify feedwater/level controls
  - j. Set up and verify Emissions Compliance
5. Training to include all safety procedures, maintenance procedures, control operations, and diagnostic procedures. Training to be provided in a single-hour continuous session to accommodate operator's availability on site.
6. Special tool / safety equipment:
  - a. Boiler/burner supplier to include in their proposal safety equipment required to perform annual inspections and maintenance per OSHA requirements, Section 29CFR,1910.146, date 4115193, Paragraphs 5.6.4.2 through 5.6.6.6 confined space requirements on rear furnace and flue gas turnaround area. Items to include respirator, tag out devices, atmospheric tester, acid suit, harness, wrist straps, life wire, and safety belt
  - b. Special Safety Training on safety procedures by a qualified trainer to be provided per OSHA Section 1910.146, Paragraph 5.6.5.2, to all owners and employees who are operating specified equipment. The cost of training to be included in boiler supplier's proposal

## 2.16 OPERATING & MAINTENANCE MANUALS

- A. Provide two (2) Operating and Maintenance manuals including cut-away views of boiler and burner, schematics including fuel trains, general instructions for maintenance and inspections, complete spare parts lists and trouble shooting procedures. Operating and maintenance manuals shall be provided including cut-away views of boiler and burner schematics including fuel trains, general instructions for maintenance and inspections, complete spare parts lists and trouble shooting procedures.
- B. A wiring diagram corresponding to the boiler shall be affixed to the boiler near the electrical panel.

## 2.17 WARRANTY DATA

- A. The entire boiler/burner package shall be guaranteed and warranted by the boiler manufacturer. Warranty shall include all parts for a period of (12) months from the date of start-up or beneficial use or 18 months from shipment, whichever comes first.

## *PART 3 EXECUTION*

### **3.01 GENERAL**

- A. Installation shall be provided by the contractor in accordance with the requirements of the codes specified hereinbefore. All of the contractor's work shall be performed by experienced workman previously engaged in boiler plant construction and shall be under the supervision of a qualified installation supervisor.

### **3.02 INSTALLATION**

- A. Install equipment in strict compliance with manufacturer's installation instructions.
- B. Install equipment in strict compliance with state and local codes and applicable NFPA standards.
- C. Maintain manufacturer's recommended clearances around sides and over top of equipment.
- D. Install components that were removed from equipment for shipping purposes.
- E. Install components that were furnished loose with equipment for field installation.
- F. Provide all interconnecting electrical control and power wiring.
- G. Provide all fuel gas vent and service piping.
- H. Provide all piping for boiler pipe connections.

### **3.03 FIELD TESTING**

- A. The manufacturer's representative shall test all boiler and burner interlocks, actuators, valves, controllers, gauges, thermometers, pilot lights, switches, etc. Any malfunctioning component shall be replaced.
- B. All adjustments to boiler, burner, and boiler control system shall be performed by the manufacturer's representative.

### **3.04 START-UP, INSTRUCTION AND WARRANTY SERVICE**

The manufacturer's representative shall provide start-up and instruction of each new boiler, including burner and boiler control system as specified herein. Start-up and instruction shall cover all components assembled and furnished by the manufacturer whether or not of his own manufacture.

# Notes