



PROFIRE S1 SERIES

TECHNICAL DATA INFORMATION PACKET

Table of Contents

ProFire S1 Series Uncontrolled Emissions S1G, S1L, S1LG

Technical Data Sheet	3
Ratings Table	4
Dimension Table	5

ProFire S1 Series Uncontrolled Emissions S1E, S1EG

Technical Data Sheet	6
Ratings Table	7
Dimension Table	8

ProFire S1 Series <30 PPM Low NOx LNS1G, LNS1LG

Technical Data Sheet	9
Ratings Table	10
Dimension Table	11

ProFire Burners

S1 Series

Technical Data Sheet

Choice of NFPA, GAP, and FM for U.S. or Canadian units

Uncontrolled Emissions Configuration (S1G, S1L, S1LG)

46.2 - 63.0 MM BTU/H NG; 330 - 450 GPH #2 OIL

Standard equipment:	Combustion Control System options:	Fuel options:
3450 RPM motor, panel signal lights (Load Demand, Low Water, Flame Failure, Fuel Valve), dry oven and gasket, combustion air proving switch, high fire air proving switch, 120/1/60 control circuit, burner mounted junction box with remote panel, hinged blast tube with right-hand swing. Gas and gas/oil units only: two butterfly rate control valves, high/low gas pressure switches, two gas shutoff cocks, main gas regulator, shipped loose gas train.	Parallel Positioning Combustion Control System with O ₂ Trim and Variable Frequency Drive (VFD)	Main Fuel: Natural gas (S1G), #2 oil - air atomized (S1L) or Combination gas/ #2 oil - air atomized (S1LG). Igniter Fuel: Natural gas and/or propane. Fuel Changeover Switch: Combination gas/oil units only (S1LG).

Series Features

◇ Optional Feature

	S1-462	S1-504	S1-546	S1-588	S1-630
Flame Safeguard					
UV Scanner	•	•	•	•	•
Mode of Operation					
Full Modulation Firing	•	•	•	•	•
Auto-Manual Firing Rate Control	• ¹	• ¹	• ¹	• ¹	• ¹
Ignition					
Gas/Electric Pilot and Ignition Transformer	•	•	•	•	•
Oil Components					
3-Way Motorized POC Valve	•	•	•	•	•
2-Way Motorized POC Valve	•	•	•	•	•
Relief Valve	•	•	•	•	•
Oil Pressure Regulator	•	•	•	•	•
Atomizing Air Proving Switch	•	•	•	•	•
Low/High Oil Pressure Switch	•	•	•	•	•
Burner Mounted Oil Metering Valve	•	•	•	•	•
Separately Mounted Air Compressor Module	•	•	•	•	•
Gas Components					
Motorized w/ POC & Motorized w/o POC	•	•	•	•	•
Motorized Valve w/ POC (2)	◇	◇	◇	◇	◇
Normally Open Vent Valve	•	•	•	•	•

¹ Standard for full modulation; optional on select parallel positioning systems

Note: A separate oil circulating pump set is required for all S1L and S1LG burners. The burner mounted unit is an oil input metering device only.

ProFire Burners

S1 Series

Standard Ratings Sheet

S1G - S1L - S1LG: Gas, #2 Oil, Gas/Oil Configuration

	Gas Input MBH	#2 Oil Input GPH	BHP @ 80% Eff.	Blower Motor HP	Separate Compressor Module Motor HP 3 Phase	Furnace Pressure ("w.c.)	Standard Gas Train Pipe Size (in.)	Gas Pressure Required (PSI)
Model No. & Frame Size								
S1-462-1	46,200	330	1,100	60	15	8	3	10
S1-504-1	50,400	360	1,200	75	15	8	3	10
S1-546-1	54,600	390	1,300	75	15	8	3	10
S1-588-2	58,800	420	1,400	75	15	8	4	10
S1-630-2	63,000	450	1,500	100	15	8	4	10

460 / 3

Input is based on fuel BTU content, listed furnace pressure and altitude of 2,000 feet or less. If altitude > 2,000 feet and < 8,000 feet, derate capacity 4% per 1,000 feet over 2,000. Consult factory for higher altitudes. If furnace pressure exceeds listed value, derate capacity 5% for every 0.5" w.c. of pressure in excess of stated. Consult factory if derate exceeds 20%. Gas input is based on natural gas with 1,000 BTU/cu.ft., 0.60 gravity, 0" w.c. furnace pressure and the aforementioned conditions. For total pressure at manifold, add furnace pressure. Oil input based on 140,000 BTU/gal and the aforementioned conditions. Consult factory for 50 Hz. applications.

ProFire Burners

S1 Series

Standard Dimension Sheet

S1G - S1L - S1LG: Gas, #2 Oil, Gas/Oil Configuration

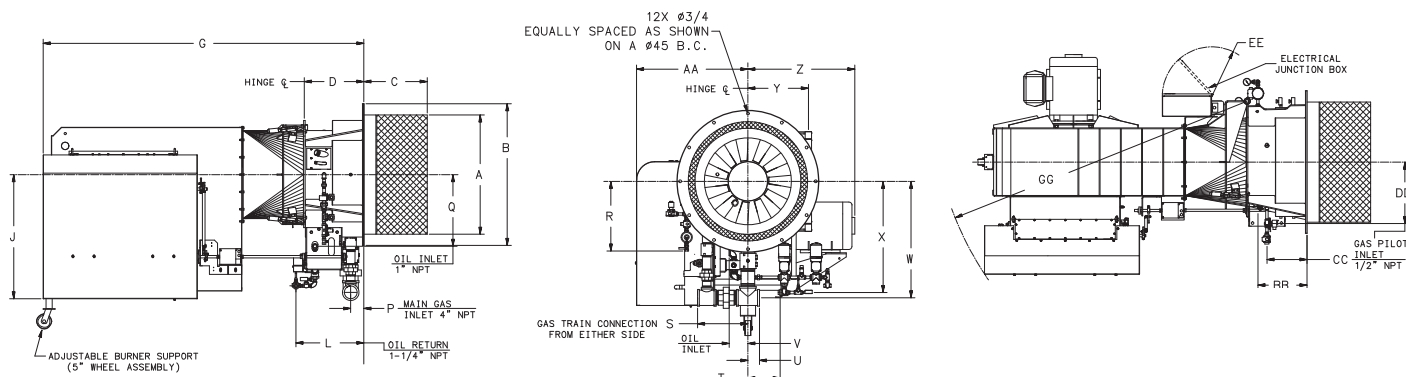

	DIM	Burner Frame Size	
		Size 1	Size 2
Length in inches			
Overall length	G	105	106 1/2
Width in inches			
Center line to right side	Z	33	46
Center line to left side	AA	33 3/4	35 3/8
Height in inches			
Center line to bottom	J	39 1/4	41 1/4
Dry oven dimensions in inches			
Diameter of dry oven	A	39 5/8	39 5/8
Depth of dry oven	C	21	21
Mounting flange dimensions in inches			
Diameter	B	47	47
Flange to hinge	D	19 3/4	19 3/4
Hinge dimensions in inches			
Center line to hinge	Y	20	20
Fan housing dimensions in inches			
Radius of the fan housing	GG	101 3/4	103 1/2
Panel door dimensions in inches			
Radius of panel door swing	EE	16 3/8	16 3/8
Gas pilot inlet dimensions in inches			
Center line to gas pilot inlet	R	23 1/8	23 1/8
Mounting flange to gas pilot inlet	CC	13 1/4	13 1/4
Center line to gas pilot inlet	DD	20 1/4	20 1/4
Main gas inlet dimensions in inches			
Mounting flange to main gas inlet	P	4 3/8	4 3/8
Center line to main gas inlet	S	16 3/4	16 3/4
Center line to main gas inlet	U	3 7/8	3 7/8
Center line to main gas inlet	W	38 5/8	38 5/8

	DIM	Burner Frame Size	
		Size 1	Size 2
Oil inlet dimensions in inches			
Center line to oil inlet	Q	23 7/8	23 7/8
Center line to oil inlet	V	6 1/4	6 1/4
Mounting flange to oil inlet	BB	16 1/4	16 1/4
Oil return dimensions in inches			
Mounting flange to oil return	L	22 1/2	22 1/2
Center line to oil return	T	10 5/8	10 5/8
Center line to oil return	X	36 7/8	36 7/8

Accompanying dimensions, while sufficiently accurate for layout purposes, must be confirmed for construction.

ProFire Burners

S1 Series

Technical Data Sheet

Uncontrolled Emissions Configuration (S1E, S1EG)

46.2 - 63.0 MM BTU/H NG; 330 - 450 GPH #2-6 OIL

UL listed with choice of NFPA, CSD-1, GAP, and FM for U.S. or Canadian units

Standard equipment:	Combustion Control System options:	Fuel options:
3450 RPM motor, panel signal lights (Load Demand, Low Water, Flame Failure, Fuel Valve), dry oven and gasket, combustion air proving switch, high fire air proving switch, 120/1/60 control circuit, burner mounted junction box with remote panel, hinged blast tube with right-hand swing. Gas and gas/oil units only: two butterfly rate control valves, high/low gas pressure switches, two gas shutoff cocks, main gas regulator, shipped loose gas train.	Parallel Positioning Combustion Control System with O ₂ Trim and Variable Frequency Drive (VFD)	Main Fuel: #6 oil - air atomized (S1E) or Combination natural gas/ #6 oil - air atomized (S1EG). Igniter Fuel: Natural gas and/or propane. Fuel Changeover Switch: Combination gas/oil units only (S1EG).

Series Features

◊ Optional Feature

	S1-462	S1-504	S1-546	S1-588	S1-630
Flame Safeguard					
IR Scanner	•	•	•	•	•
Mode of Operation					
Full Modulation Firing	•	•	•	•	•
Auto-Manual Firing Rate Control	• ¹	• ¹	• ¹	• ¹	• ¹
Ignition					
Gas/Electric Pilot and Ignition Transformer	•	•	•	•	•
Oil Components					
3-Way Motorized POC Valve	•	•	•	•	•
2-Way Motorized POC Valve	•	•	•	•	•
Relief Valve	•	•	•	•	•
Oil Pressure Regulator	•	•	•	•	•
Atomizing Air Proving Switch	•	•	•	•	•
Low/High Oil Pressure Switch	•	•	•	•	•
Burner Mounted Oil Metering Valve	•	•	•	•	•
Separately Mounted Air Compressor Module	•	•	•	•	•
Gas Components					
Motorized w/ POC & Motorized w/o POC	•	•	•	•	•
Motorized Valve w/ POC (2)	◊	◊	◊	◊	◊
Normally Open Vent Valve	•	•	•	•	•

¹ Standard for full modulation; optional on select parallel positioning systems

Note: A separate oil circulating pump set is required for all S1E and S1EG burners.

The burner mounted unit is an oil input metering device only.

ProFire Burners

S1 Series

Standard Ratings Sheet

S1E - S1EG: #2-6 Oil, Gas/Oil Configuration

	Gas Input MBH	#6 Oil Input GPH	BHP @ 80% Eff.	Blower Motor HP	Separate Compressor Module Motor HP 3 Phase	Furnace Pressure ("w.c.)	Standard Gas Train Pipe Size (in.)	Gas Pressure Required (PSI)
Model No. & Frame Size								
S1-462-1	46,200	308	1,100	60	15	8	3	10
S1-504-1	50,400	336	1,200	75	15	8	3	10
S1-546-1	54,600	364	1,300	75	15	8	3	10
S1-588-2	58,800	392	1,400	75	15	8	4	10
S1-630-2	63,000	420	1,500	100	15	8	4	10

460 / 3

Input is based on fuel BTU content, listed furnace pressure and altitude of 2,000 feet or less. If altitude > 2,000 feet and < 8,000 feet, derate capacity 4% per 1,000 feet over 2,000. Consult factory for higher altitudes. If furnace pressure exceeds listed value, derate capacity 5% for every 0.5" w.c. of pressure in excess of stated. Consult factory if derate exceeds 20%. Gas input is based on natural gas with 1,000 BTU/cu.ft., 0.60 gravity, 0" w.c. furnace pressure and the aforementioned conditions. For total pressure at manifold, add furnace pressure. Oil input based on 150,000 BTU/gal and the aforementioned conditions. Consult factory for 50 Hz. applications.

ProFire Burners S1 Series

<30 PPM Low NOx Dimension Sheet

LNS1G - LNS1LG: Gas, Gas/Oil Configuration

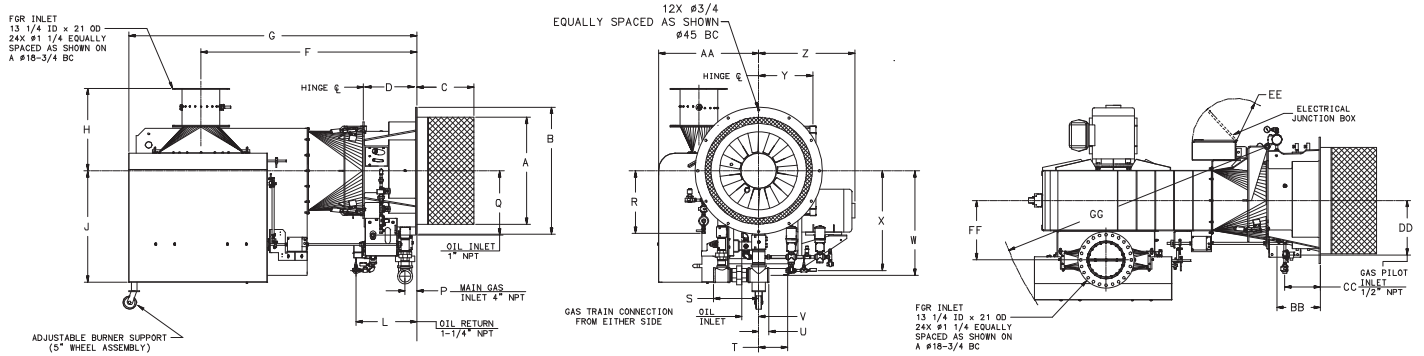

	DIM	Burner Frame Size	
		Size 1	Size 2
Length in inches			
Overall length	G	105	106 1/2
Width in inches			
Center line to right side	Z	33	46
Center line to left side	AA	33 3/4	35 3/8
Height in inches			
Center line to top of FGR	H	28 1/2	30 1/2
Center line to bottom	J	39 1/4	41 1/4
Dry oven dimensions in inches			
Diameter of dry oven	A	39 5/8	35 3/8
Depth of dry oven	C	21	21
Mounting flange dimensions in inches			
Diameter	B	47	47
Flange to hinge	D	19 3/4	19 3/4
Hinge dimensions in inches			
Center line to hinge	Y	20	20
Fan housing dimensions in inches			
Radius of the fan housing	GG	101 3/4	103 1/2
Panel door dimensions in inches			
Radius of panel door swing	EE	16 3/8	16 3/8
Flue gas recirculation (FGR) dimensions in inches			
Mounting flange to center line of FGR	F	78 7/8	82 1/2
Center line of burner to center line of FGR	FF	19	20 5/8
Gas pilot inlet dimensions in inches			
Center line to gas pilot inlet	R	23 1/8	23 1/8
Mounting flange to gas pilot inlet	CC	13 1/4	13 1/4
Center line to gas pilot inlet	DD	20 1/4	20 1/4

	DIM	Burner Frame Size	
		Size 1	Size 2
Main gas inlet dimensions in inches			
Mounting flange to main gas inlet	P	4 3/8	4 3/8
Center line to main gas inlet	S	16 3/4	16 3/4
Center line to main gas inlet	U	3 7/8	3 7/8
Center line to main gas inlet	W	38 5/8	38 5/8
Oil inlet dimensions in inches			
Center line to oil inlet	Q	23 7/8	23 7/8
Center line to oil inlet	V	6 1/4	6 1/4
Mounting flange to oil inlet	BB	16 1/4	16 1/4
Oil return dimensions in inches			
Mounting flange to oil return	L	22 1/2	22 1/2
Center line to oil return	T	10 5/8	10 5/8
Center line to oil return	X	36 7/8	36 7/8

Accompanying dimensions, while sufficiently accurate for layout purposes, must be confirmed for construction.

ProFire Burners

S1 Series

Technical Data Sheet

Choice of NFPA, GAP, and FM for U.S. or Canadian units

<30 PPM Low NOx Configuration (LNS1G, LNS1LG)

42 - 63 MM BTU/H NG; 300 - 450 GPH #2 OIL

Standard equipment:	Combustion Control System options:	Fuel options:
3450 RPM motor, panel signal lights (Load Demand, Low Water, Flame Failure, Fuel Valve), FGR, dry oven and gasket, combustion air proving switch, high fire air proving switch, 120/1/60 control circuit, burner mounted junction box with remote panel, hinged blast tube with right-hand swing. Gas and gas/oil units only: two butterfly rate control valves, high/low gas pressure switches, two gas shutoff cocks, main gas regulator, shipped loose gas train.	Parallel Positioning Combustion Control System with O ₂ Trim and Variable Frequency Drive (VFD)	Main Fuel: Natural gas (LNS1G), or Combination gas/ #2 oil - air atomized (LNS1LG). Igniter Fuel: Natural gas and/or propane. Fuel Changeover Switch: Combination gas/oil units only (LNS1LG).

Series Features

◊ Optional Feature



	LNS1-462	LNS1-504	LNS1-546	LNS1-588	LNS1-630
Flame Safeguard					
UV Scanner	•	•	•	•	•
Mode of Operation					
Full Modulation Firing	•	•	•	•	•
Auto-Manual Firing Rate Control	• ¹	• ¹	• ¹	• ¹	• ¹
Ignition					
Gas/Electric Pilot and Ignition Transformer	•	•	•	•	•
Oil Components					
3-Way Motorized POC Valve	•	•	•	•	•
2-Way Motorized POC Valve	•	•	•	•	•
Relief Valve	•	•	•	•	•
Oil Pressure Regulator	•	•	•	•	•
Atomizing Air Proving Switch	•	•	•	•	•
Low/High Oil Pressure Switch	•	•	•	•	•
Burner Mounted Oil Metering Valve	•	•	•	•	•
Separately Mounted Air Compressor Module	•	•	•	•	•
Gas Components					
Motorized w/ POC & Motorized w/o POC	•	•	•	•	•
Motorized Valve w/ POC (2)	◊	◊	◊	◊	◊
Normally Open Vent Valve	•	•	•	•	•

¹ Standard for full modulation; optional on select parallel positioning systems

Note: A separate oil circulating pump set is required for all LNS1LG burners.

The burner mounted unit is an oil input metering device only.

ProFire Burners S1 Series

<30 PPM Low NOx Ratings Sheet

LNS1G - LNS1LG: Gas, Gas/Oil Configuration

	Gas Input MBH	#2 Oil Input GPH	BHP @ 80% Eff.	Blower Motor HP	Separate Compressor Module Motor HP 3 Phase	Furnace Pressure ("w.c.)	Standard Gas Train Pipe Size (in.)	Gas Pressure Required (PSI)	FGR Line Piping Size (in.)
Model No. & Frame Size									
LNS1-462-1	42,000	300	1,000	60	15	8	3	10	14
LNS1-504-1	46,200	330	1,100	75	15	8	3	10	14
LNS1-546-1	50,400	360	1,200	100	15	8	3	10	14
LNS1-588-2	54,600	390	1,300	100	15	8	3	10	14
LNS1-630-2	58,800	420	1,400	125	15	8	3	10	14
LNS1-630-2	63,000	450	1,500	125	15	8	4	10	14

460 / 3

Input is based on fuel BTU content, listed furnace pressure and altitude of 2,000 feet or less. If altitude > 2,000 feet and < 8,000 feet, derate capacity 4% per 1,000 feet over 2,000. Consult factory for higher altitudes. If furnace pressure exceeds listed value, derate capacity 5% for every 0.5" w.c. of pressure in excess of stated. Consult factory if derate exceeds 20%. Gas input is based on natural gas with 1,000 BTU/cu.ft., 0.60 gravity, 0" w.c. furnace pressure and the aforementioned conditions. For total pressure at manifold, add furnace pressure. Oil input based on 140,000 BTU/gal and the aforementioned conditions. Consult factory for 50 Hz. applications.

ProFire Burners S1 Series

<30 PPM Low NOx Dimension Sheet

LNS1G - LNS1LG: Gas, Gas/Oil Configuration

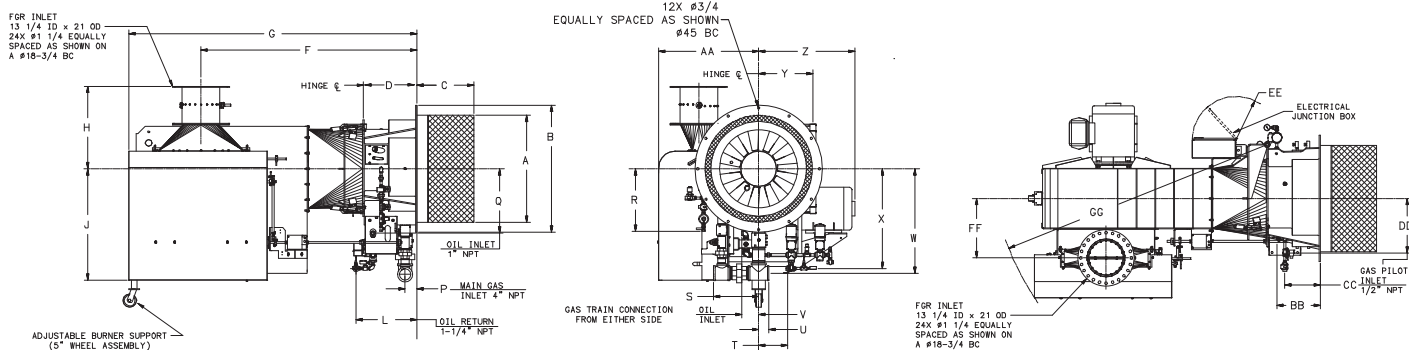

	DIM	Burner Frame Size	
		Size 1	Size 2
Length in inches			
Overall length	G	105	106 1/2
Width in inches			
Center line to right side	Z	33	46
Center line to left side	AA	33 3/4	35 3/8
Height in inches			
Center line to top of FGR	H	28 1/2	30 1/2
Center line to bottom	J	39 1/4	41 1/4
Dry oven dimensions in inches			
Diameter of dry oven	A	39 5/8	35 3/8
Depth of dry oven	C	21	21
Mounting flange dimensions in inches			
Diameter	B	47	47
Flange to hinge	D	19 3/4	19 3/4
Hinge dimensions in inches			
Center line to hinge	Y	20	20
Fan housing dimensions in inches			
Radius of the fan housing	GG	101 3/4	103 1/2
Panel door dimensions in inches			
Radius of panel door swing	EE	16 3/8	16 3/8
Flue gas recirculation (FGR) dimensions in inches			
Mounting flange to center line of FGR	F	78 7/8	82 1/2
Center line of burner to center line of FGR	FF	19	20 5/8
Gas pilot inlet dimensions in inches			
Center line to gas pilot inlet	R	23 1/8	23 1/8
Mounting flange to gas pilot inlet	CC	13 1/4	13 1/4
Center line to gas pilot inlet	DD	20 1/4	20 1/4

	DIM	Burner Frame Size	
		Size 1	Size 2
Main gas inlet dimensions in inches			
Mounting flange to main gas inlet	P	4 3/8	4 3/8
Center line to main gas inlet	S	16 3/4	16 3/4
Center line to main gas inlet	U	3 7/8	3 7/8
Center line to main gas inlet	W	38 5/8	38 5/8
Oil inlet dimensions in inches			
Center line to oil inlet	Q	23 7/8	23 7/8
Center line to oil inlet	V	6 1/4	6 1/4
Mounting flange to oil inlet	BB	16 1/4	16 1/4
Oil return dimensions in inches			
Mounting flange to oil return	L	22 1/2	22 1/2
Center line to oil return	T	10 5/8	10 5/8
Center line to oil return	X	36 7/8	36 7/8

Accompanying dimensions, while sufficiently accurate for layout purposes, must be confirmed for construction.



Packaged Burner Systems
351 21st Street, Monroe, WI 53566 USA
608.325.3141 · info@cleaverbrooks.com
cleaverbrooks.com