

ProFire LNXLG Series Product Information
Horizontal Configuration
< 30 PPM Straight Gas
67.2 - 92.4 MMBtu



The LNXL series straight gas burner is a forced draft packaged burner system. A backward curved impeller provides combustion air for various furnace pressures or high altitude applications. The rear-access cover is hinged for convenient inspection or service of the firing head components. Main gas train components are shipped loose.

Flue gas recirculation (FGR) is drawn through the burner blower assembly properly sized for the required NOx emission levels. An FGR control valve is positioned by the FGR system to provide FGR at all firing rates. The system is equipped with ANSI flanges to allow easy installation into the FGR piping.

The LNXL series is guaranteed to provide less than 30 ppm NOx, corrected at 3% O₂ dry throughout the firing range when firing natural gas.

STANDARD EQUIPMENT

- 120/1/60 Control Circuit
- Panel Signal Lights: Power On, Main Fuel, Ignition, and Flame Failure
- Burner Mounted Junction Box w/Remote Panel
- Combustion Air Proving Switch
- Air Dampers w/Silencer
- Burner Mounting Flange
- Gas-Electric Ignition
- Hinged Rear Access Cover



SERIES FEATURES

S = STANDARD
O = OPTIONAL
N/A = NOT AVAILABLE

	LNXLG-672	LNXLG-756	LNXLG-840	LNXLG-924
Flame Safeguard with UV Scanner (IR Scanner Available)	S	S	S	S
1800 RPM Combustion Fan	S	S	S	S
Full Modulation Firing	S	S	S	S
Parallel Positioning System	S	S	S	S
Dry Oven	O	O	O	O
O ₂ Trim	O	O	O	O
Variable Frequency Drive (VFD)	O	O	O	O
High & Low Gas Pressure Switches	S	S	S	S
Normally Open (N.O.) Vent Valve	S	S	S	S
Main Gas Regulator & (2) Gas Shutoff Cocks	S	S	S	S
Gas Flow Control Valves Mounted on Burner Piping	S	S	S	S

SPECIFICATIONS & DIMENSIONS

BURNER MODEL	FRAME SIZE	GAS INPUT (MBH)	BHP @ 80% EFF.	MOTOR HP	BLOWER MOTOR VOLT/ PH 60 HZ.	FURNACE PRESS. ("W.C.)	GAS PRESSURE REQUIRED (PSI)	FGR LINE PIPING SIZE
LNXLG-672	3	67,200	1,600	100	460/3	8.3	10	18
LNXLG-756	3	75,600	1,800	100	460/3	8.8	10	18
LNXLG-840	3	84,000	2,000	125	460/3	8.8	10	20
LNXLG-924	3	92,400	2,200	125	460/3	8.9	10	20

NOTES:

- Gas input based on natural gas at 1,000 Btu/cu.ft. and 0.60 gravity.
- Gas pressure based on zero furnace pressure. For total pressure at manifold, add furnace pressure.
- Boiler overall efficiency of 80% estimated.
- Blower wheel and motor HP is based on altitude up to 2,000 ft. above sea level. For higher altitude or 50 Hz. applications, consult factory.
- Firing at higher furnace pressures de-rates the burner by approximately 5% per 1/2" of additional pressure, consult factory.
- 900-1,500 HP models are available, consult factory.
- Other motor voltages available, consult factory.

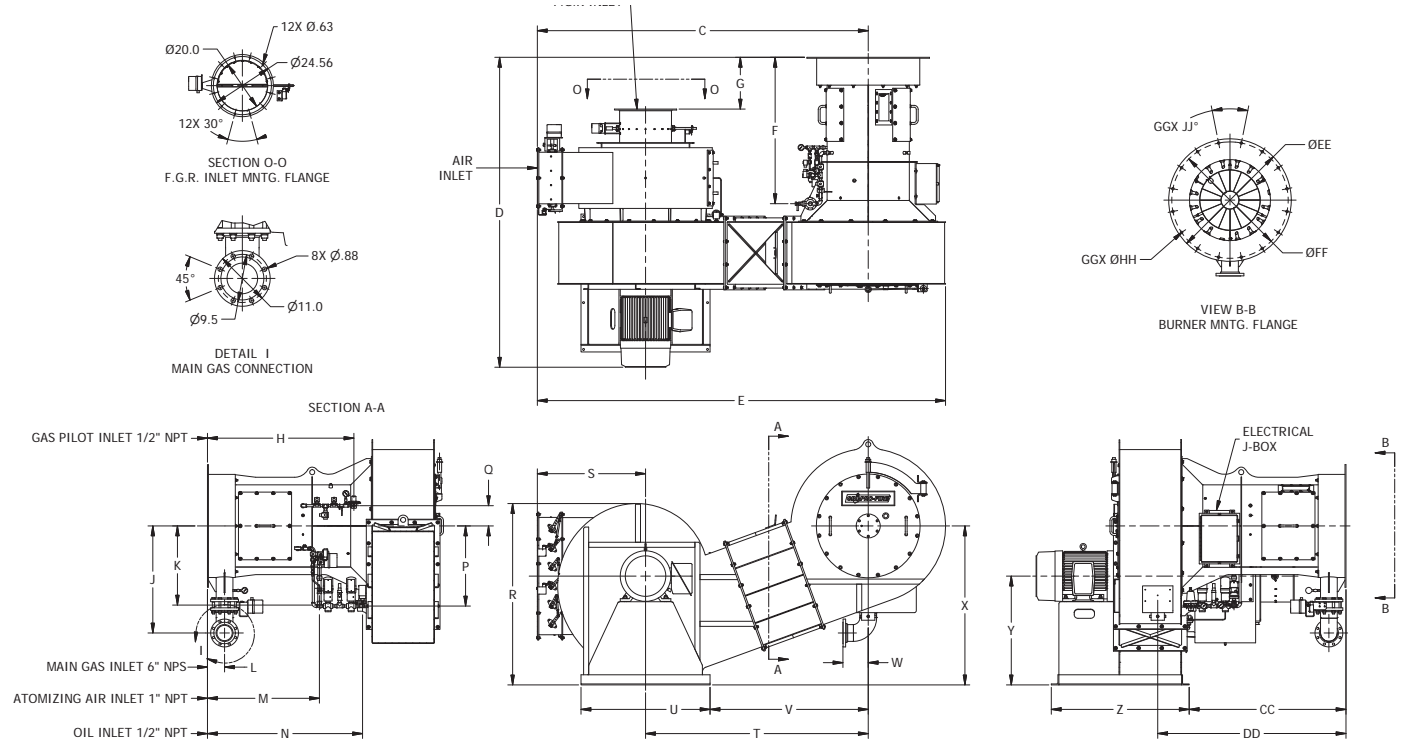

STANDARD CONFIGURATION

BURNER MODEL	C	D	E	F	G	H	J	K	L	M	N	P	Q	R	S
SIZE 3	130 3/4	122 1/2	161 3/8	58	20 1/2	58	42 3/8	31 3/8	6 7/8	44 3/8	61 3/8	31 3/4	8	71 3/4	42 7/8

BURNER MODEL	T	U	V	W	X	Y	Z	CC	DD	EE	FF	GG	HH	JJ
SIZE 3	88	51	62 1/2	10	62 7/8	43	54 1/2	62	74 1/2	48 1/2	46	16	1	22 1/2°